



ELECTRICAL

INSTALLATION ENGINEER

NEWS LETTER

TAMILNADU ELECTRICAL INSTALLATION ENGINEERS' ASSOCIATION 'A' GRADE (Regn. No. 211/1992)

Old No.82 / New No. 123, Lloyds Enclave, Avvai Shanmugam Road, Royapettah, Chennai - 600 014.

Phone : 2811 1300 Fax : 2811 1908 Email : tnagrade@gmail.com Website : www.teiea.com

ISSUE NO. 111

VOL : No. 10/2015

MONTHLY ISSUE NO. 5

PRIVATE CIRCULATION ONLY

MAY 2015

SERVING THE POWER SECTOR FOR MORE THAN 40 YEARS

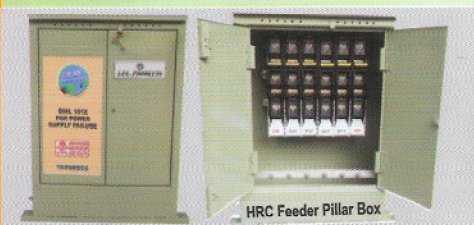
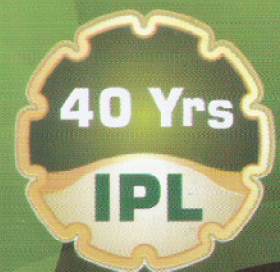
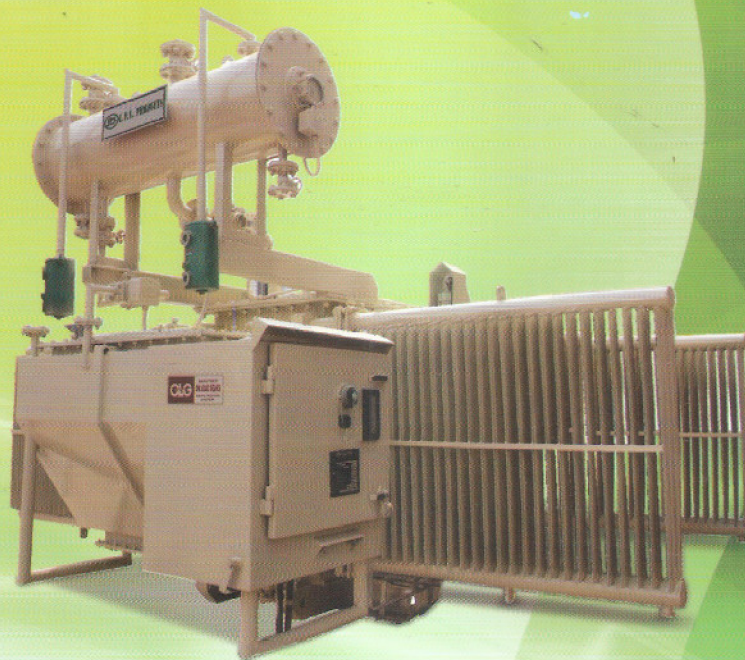

HRC Feeder Pillar Box

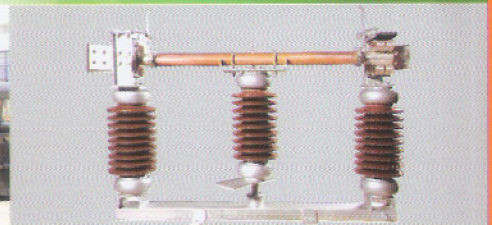

MARKETED BY:

M/s. Faith Power Solutions,
1, Ramanujam Street, Choolaimedu, High Road,
Choolaimedu, Chennai - 600 094
Saleschn@faithpower.in | NSP@faithpower.in
www.faipowersolutions.in

I.P.L PRODUCTS

An ISO 9001 - 2008 Company
Manufacturer of Distribution Transformers, Isolators & Feeder Pillar Box

Unit - I: Isolator & Feeder Pillar Box Manufacturing Unit:
K-2, Thiru-vi-ka Industrial Estate, Guindy, Chennai - 600 032

Unit - II: Transformer Manufacturing Unit:
No.48, SIDCO Industrial Estate, Thirumudivakkam, Chennai - 44

CONTACT: 044 - 4269 7099 | +91-77086 81999 | +91-99400 21859

EDITORIAL

Dear Members, Fellow Professionals, Friends and Well wishers,

Seasons Greetings to One and All!!

When this Editorial was being written, the sad news of Nepal Earth Quake with death toll rising to over 3000 and the injured and the affected numbers swelling to huge numbers really shook us. It is satisfying to note the prompt and vast measures initiated by our Government under the direct orders and supervision of the Prime Minister. We wish and extend our prayers for the normalcy to return as early as possible. The News that this Danger was known to the seismologists of UK in advance who were trying to examine what could be done in terms of preparation and so on, but the cruelty of Nature is that it did not allow them to predict when the Quake was going to strike.

We are Celebrating the **NATIONAL TECHNOLOGY DAY** during May on the 11th of May, which makes us feel proud about the Technological Developments world over and in our country in the last 115 years. But the fact is that the world has burnt away lot of fossils during this period speeding up the Climatic Change problems and the Climate Change experts of the world are also expressing fear about India, that, in coming decades, it may burn vast amounts of dirty coal in very inefficient ways which could be devastating. The moral, therefore, is that we should work for and adopt Technologies which can help efficient burning of our deposits of Coal in India and also work for adopting advanced Technologies for all sources of Renewable Energy where India's potentials are huge. Some of the examples of Renewable Energy Technologies can be - Off shore Wind, Biomass to Bio Crude / Bio Fuel, Advanced Combustion and Gasification Technologies to address all kinds of wastes to convert to Energy and so on. Energy is required for Development and more and more of it is required when we have ambitious plans. Technologies can also help India to work for Energy Freedom, utilizing our reserves of Coal, limited reserves of Oil, and vast availability of Renewable Energy Sources of Biomass, Wind and Solar.

Technology can also help us for Rain Water and Flood Water harvesting - Flood Water harvesting through Water Grids spread through the country - for elimination of crores of pump sets now used for lift irrigation in Agriculture. Study says that water grids can help save energies in Transportation and can also help Generate thousands of Megawatts of Hydro Electricity.

Another area of concern where advancements in Technologies can help is the Efficient Use of Energy. India scores very poor when the GDPs of different countries of the world are compared along with the quantum of energy consumed for producing those GDPs. This is a reflection of poor efficiency in all uses of energy in our country, be it roads and transports or agriculture or industries or homes or other utilities. Analysis will show that through improvement of efficiencies in all the areas can actually result in energy surplus even with the present levels of Generation. This is not an imagination, but a reality we have to believe in and work for.

We thank all those members who have helped us by participating in the advertisements appearing for the issue April 2015 - Max Electric Co., Tandem Enterprises, OBO Bettermann India Pvt. Ltd., EA Facilities Services Pvt. Ltd., Emaar Electricals, Power Links, P2 Power Solutions Pvt. Ltd., Wilson Power and Distribution Technologies Pvt. Ltd., Cape Electric Pvt. Ltd., Ashlok Safe Earthing Electrode Ltd., Abirami Electricals, Galaxy Earthing Electrodes Pvt. Ltd., FLIR Systems India Pvt. Ltd., Ledgeo Lights Pvt Ltd., Universal Earthing Systems Pvt. Ltd., Supreme Power Equipment Pvt. Ltd., Sivasakthi Electricals, Power Cable Corporation, I.P.L. Products.

EDITOR

Take CHARGE for Electrical Safety.

	PARTICULARS	PAGE NO.
President : U. BASKARAN Secretary : K. KANNAN Treasurer : P. SUYAMBU	Editorial	7
	Contents	8
	Members Details	9
Editor : G. VENKATESH Printer : M. VENKATARAMAN Advisor : S. MAHADEVAN	EVENTS	10
	Know Thy Power Network – 92	11-12
	Hybrid Cars: Parallel Vs. Series	12
No part of the material protected by this copyright notice may be reproduced or utilised in any form or by any means, the electronic or mechanical including photocopying, recording, or by any information storage and retrieval systems, without prior written permission from the copyright owner.	Energy Storage India 2014 concludes with Broad consensus on opportunities for storage	13
	'We must harvest Renewable Energy in a Decentralized manner'	14-15
	Indian LED Industry set to touch Rs.21,600 cr by 2020	15
	Gujarat may get India's first offshore Wind Power Project	16
	Vector Solutions	17
	ABB better World Series	18-20
	Fame	20
	Solar Impulse II – Update	21
	The Three Principles of Sustainable home Cooling	22-23
	Velocical Shrinks the rim drive to "World's Lightest" E-Bike Drive	23
	An Eco Town UK	24
	Releasing of Revised Edition of Guideline book – 25.03.2015 – Photos	25-26
	Osram delivers new IR LED for Biometric ID applications	33
	Powering Engineers Through Training - L & T	34-35
	New York to build World's most Powerful Smart Energy Lab	36
	Boston-Power Aims to Rival Tesla with Gigawatt Battery Factories	37-38
	Goodyear BHO3 concept Tire Generates Electricity	38
	Record decline of Ice sheets: for the first time scientists Map elevation changes of Greenlandic and Antarctic Glaciers	39
	Energy Conservation Through Energy Efficiency – 3	40-42
	What made the difference – (Self-Confidence)	42
	Achieving Longevity	43
	Humour – Tell the Truth	43
	வந்து பாருங்கள் – ஈஞ்சம்பாக்கம்	44
	20 Most Peaceful Countries in the World – 6	44
	சிறு தானியங்களினால் தீரும் நோய்கள்	45
	Aruna Asaf Ali (1909-1996)	46-47
	Humour – Collection of Tongue Twisters	47
	Wilhelm Weber (1804 – 1891)	48
	Power Your Mind	48
	Tirukkural and Management in a 'Nutshell' – 25	49
Home Festivals – 6	49	
Prototype Electric Vehicle Passes first test on Road to Antarctica	50-51	
	ADVERTISEMENTS	PAGE NO.
	Abirami Electricals	4
	Ashlok Safe Earthing Electrode Ltd.	56
	Cape Electric Pvt. Ltd.	3
	Electrotherm India Ltd.	32
	Faith Power Solutions – I.P.L. Products	1
	Flir Systems India Pvt. Ltd.	55
	Galaxy Earthing Electrodes Pvt. Ltd.	2
	JL Seagull Power Products	5
	Ledgeo Ligts Pvt. Ltd.	52
	Max Electric Co.	27
	OBO Bettermann India Pvt. Ltd.	31
	P2 Power Solutions Pvt. Ltd.	54
	Power Links	9
	Supreme Power Equipment Pvt. Ltd.,	6
	Universal Earthing Systems Pvt. Ltd.	30
	Velohar Infra Pvt. Ltd.	29
	Vie Soleil	28
	Wilson Power and Distribution Technologies Pvt. Ltd.	53

**YOUR CONTRIBUTION
TOWARDS NEWS LETTER****(A) FOR BLACK &
WHITE ONLY****1. Full Page (Per Issue)
Rs. 2500****(B) FOR FOUR
COLOUR PRINTING****1. Full Page (Per Issue)
Rs. 5000****Same Size Positives
CD/Zip
to be supplied
by the Advertiser**

Demand Draft be drawn in favour of the "Tamilnadu Electrical Installation Engineers' Association 'A' Grade" payable at Chennai

MEMBERS DETAILS

S.No.	Company Name	License No.	District	Contact No.
31.	Devee Enterprises Electricals P. Ltd.	EA 2184	Chennai	044-42184476, 99401 63476
32.	Ecube Projects	EA 2890	Chennai	044-43566688, 95431 91961
33.	Elco Engineering	EA 1462	Chennai	044-24914738
34.	Elecproj India	EA 1859	Chennai	044-24852230, 98407 90077
35.	Electro Mechanical Engineers	EA 2117	Chennai	044-24984887, 94980 27093
36.	Elneed Technologies Ltd.	EA 2045	Chennai	044-24491595, 94449 76737
37.	Elsytec Engineers & Consultants P. Ltd.	EA 2332	Chennai	044-23719002, 94449 54745
38.	Emaar Electricals	EA 1212	Chennai	044-23741902, 98409 36400
39.	Eskay Enterprises	EA 1764	Chennai	044-23661051, 94440 63691
40.	Ess Enn Power Controls P Ltd.	EA 2122	Chennai	044-26512296, 72999 09466
41.	Ess Yen Electricals P. Ltd.	EA 2095	Chennai	044-28141721, 98410 26136
42.	EA Facilities Services P. Ltd.	EA 2058	Chennai	044-26646266, 96777 60568
43.	Essar Electricals	EA 2396	Chennai	044-43538542, 98406 28053
44.	Esswin Electro Controls P. Ltd.	EA 2911	Chennai	087555 13755
45.	Everest Electrical Enterprises P. Ltd.	ESA 427	Chennai	044-24869024, 94440 59023



POWER LINKS

94/95, Triplicane High Road,
Chennai - 600 005.

Ph : 28420695, Mobile : 9282143549

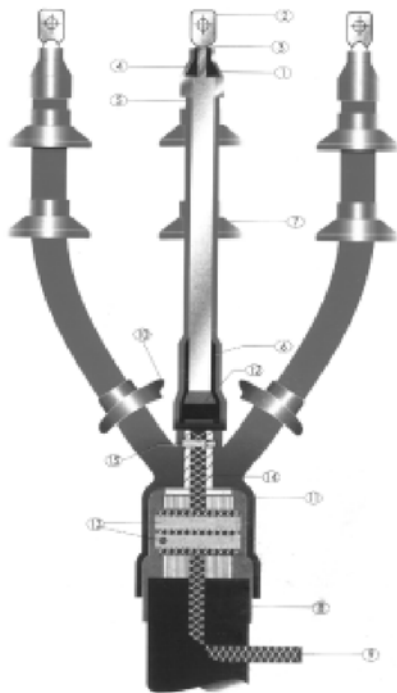

- **HEAT SHRINKABLE &**
 - **EPOXY COMPOUND TYPE**
- ### CABLE JOINTING KITS

From

1. 1 KV (LT) to 33 KV (HT)
FREE INSTALLATION SERVICE

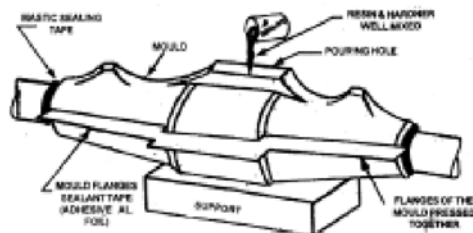

EVENTS

5th Annual Conference, Exhibition and Awards

Global Solar EPC Summit 2015

Events Profile: The 14th annual POWER-GEN India & Central Asia and 2nd edition of DistribuTECH India exhibition and conference returns to New Delhi in 2015. Together, the two events will create the complete energy package with representation from leading international power industry companies from across the entire power generation, renewable, hydro, distribution and transmission sectors.

Date: 14th – 16th May 2015

Venue: Pragati Maidan, New Delhi, India

Website: http://www.indiapowerevents.com/index.html#leftinheritedtop_tabs_2



Events Profile: Aimed at exploring more strategic moves needed besides policy incentives to break the ice for China's stagnant electric vehicle sales, the event this year will be gathering nearly 200 top professionals from across the value chain including automakers, battery & battery material suppliers, EV & hybrid powertrain developers, EV charging solution providers, battery management technology vendors, auto parts & components manufacturers, software suppliers, electricity distributors, financial institutions, and policymakers, etc.

Date: 3rd – 4th May 2015

Venue: Beijing, China

Website: <http://www.newenergyvehicles.com/>



Events Profile: Global Solar EPC Summit India 2015 Annual Event, is India's premier solar energy conference, presenting an international platform for the solar energy industry

Date: 04th – 05th June 2015

Venue: Hotel Radisson Blu, Dwarka, New Delhi, India

Website: <http://epc.solarquarter.com/>



Events Profile: POWER-GEN Africa and its sister event DistribuTECH Africa, will once again provide comprehensive coverage of the power needs, resources and issues facing the electricity generation industries across sub-Saharan Africa.

Date: 15th – 17th July 2015

Venue: Cape Town International Convention Centre, Republic of South Africa

Website: http://www.powergenafrika.com/index.html#pgaf_3



Events Profile: Ministry of New and Renewable Energy, Government of India: pushing top agenda with a 2022 generation target of projects in Renewables Energy Sectors in India 100 GW of Solar, 60 GW of Wind, 10 GW of Bio-Energy & 5 GW of Small Hydro

Date: 21st – 23rd August 2015

Venue: Expo & Convention Centre, Manekshaw Centre, Delhi, India

Website: <http://wretc.in/>

KNOW THY POWER NETWORK - 92

The structure of this article constitutes three parts

- the first part deals with the problems faced by the customers in the invisible cyber world.
- the second part furnishes the details of some of the innovative items / terms in the digitalized, smart world and
- the third and the last part gives useful information on our routine topic viz. **“Smart Grid”**.

None can deny that we are in need of security in physical as well as in cyber space. We cannot tread freely or as we like in cyber areas because when we enter the cyber space or connected / linked ourselves to the cyber space, we are not free; we are vulnerable and closely tracked / followed by so many invisible agencies. We have no security or protection at all in that cyber space. Everyone will agree that cyber security needs to be given the highest priority; yet in India, we do not have any notable cyber security policy as practiced in USA or other developed countries. Till sound cyber security measures are undertaken by our governments, we have to keep ourselves very careful i.e. we have to adopt proper **“Cyber Discipline or Cyber Hygiene”**. In this context, it may also be noted that no roles and responsibilities have been assigned for cyber security at the international level. It is yet in the incipient stage. So we should be very careful, when enter into the cyber space; it is more or less equal to roaming in a *“thick forest without any guide”*. Then imagine your fate. As a part of cyber discipline, we should not click or enter into any random “spam” or “untested websites”; otherwise, we are exposed to or vulnerable to all kinds of “malwares” or likely to be caught by some “unknown source or force”. We must always be in a position to control all our data and other movements. We should carefully decide what data can be shared in a cyber space. To put simply, when you open the doors of your house freely to the outer world, *you can face the entry of many unknown or unwanted persons. Likewise when you open your system to the cyber world, you can experience the unwanted entry of many “malicious actors”*. Among them, there may be some criminals stealing your identity or international gangs hacking your bank accounts. *When this be the case with the ordinary persons like ourselves, Imagine the fate of valuable data and operations in the vital Smart Grid and what highest security measures are needed to safeguard all our data and other vital information / operations.* It is apt to quote the experience of ‘Iran’ in this context.

The **“STUX NET”** software worm that enter in their system simply crippled their nuclear programmes in no time. This had happened five years ago. Our enemies always target our strategic networks like energy grids, financial and communication infrastructures.

This part of the article deals with the some of the latest smart items / terms for your grasping or understanding.

I Smart Insulin Job

It is a kind of insulin that is simply self adjusting or automatically meet the needs of the body blood sugar level. It lasts for nearly 14 hours. It could be useful for type – I diabetes. It is still under experimental level. It self activates when the blood sugar level shoots or goes up. This smart insulin would keep circulating in the body and turn on when needed. It could repeatedly and automatically cover the blood sugar level. The main point to be focused is that this smart insulin is normally in the *“domant or sleep mode”*; when the blood sugar level rises beyond a pre set level, it simply turns on or switches on and supply the required level of insulin.

II Smart Spy

All developed countries, cyber snoops both on *“foes and friends”* i.e. their spies reach both an *“ally or adversary”*. They will reach any country at anytime and monitor / watch all their activities closely. All countries are always in their **“Cyber loop”** – no exception. A good example is USA and China – the countries who are among the very smart cyber spies in the World.

III Smart Bag

You will agree that we are in the **“Plug Age”** or **“Smart Age”**. Now suitcases are designed with a control that would help to track it with the help of modern smart phone. It has blue tooth – enabled lock, GPS trackers and USB port for recharging. Such bags can be tracked from “air port” to air port. It has a laptop pocket just like a calculator in a diary. This connected smart bag helps to solve all the problems presently faced by the travellers all over the world.

Now it is time for us to turn our attention on our routine topic **“Smart Grid”**. Hope you all will be pleased to reconnect to the Smart Grid, a part of the future grid that provides the same efficiency, precision and inter connectivity as the billions of micro processors that it will power. As outlined earlier, the defence of cyber and physical interdependent structures should always need a special focus. Some of the areas that need attention for the in-depth understanding of this Smart Grid which is an integrated unit containing power, sensing, communication and control networks.

- Monitoring and analysis, automation and control, materials science, power electronics and integrated distributed energy sources.
- Sensing, communication, data management, modelling, dynamic interaction in interdependent layered networks, disturbance propagation in networks forecasting and handling uncertainty and risk.
- Digital control of the energy infrastructure.
- Integrated energy, information and communication for the end users.
- Transformation of the existing meters into a secure, two way energy and information portal.
- Educating the stake holders and operating personnel about the vulnerabilities and threats that are likely to be faced / experienced in Smart Grid which are different from the disturbances that are normally faced in the physical electricity grid.

So prior to the deployment and establishment of Smart Grid Technologies on a wider scale, significant challenges are to be overcome. Cyber security and interoperability are the two key challenges faced during the Smart Grid transformation. Cyber security should always be a part of it. Further it may be noted that most of the vulnerabilities are not the result of a single mistake or configuration - error but of numerous latent organizational conditions. In this type of complex networks, the human participants themselves are both the most susceptible to failure and also the most adaptable in the management of recovery. So focus need to be made on the proper and sustained training of the personnel controlling the Smart Grid operations to respond to a wide variety of emergencies. Please note that no amount of technology can replace the well-trained personnel.

With this I would like to “*sign off*”. Let us meet next month.

(To be continued...)



V. Sankaranarayanan, B.E., FIE,
Former Addl. Chief Engineer/TNEB
E-mail : vs_n_4617@rediffmail.com
Mobile: 98402 07703

HYBRID CARS: PARALLEL VS. SERIES

New variations on a very old idea

The hybrid car, powered by both an Internal Combustion Engine (ICE) and a battery-driven electric motor, is not a new concept. The first hybrid was built in 1901 by Ferdinand Porsche, then a young engineer at the Lohner Carriage Works in Vienna, Austria. Porsche’s idea was to replace two tons of lead acid batteries in the company’s electric cars with a relatively lightweight gasoline engine. The gasoline engine drove a generator to recharge a smaller battery feeding electric motors in the wheel hubs. By 1905, the Belgian engineer Henri Pieper combined the motor and generator into a single unit and invented a single-lever control system that took care of all the drive and recharging functions, including regenerative braking. He got a U.S. patent on his system in 1909. In 1914, Hermann Lemp at General Electric figured out how to scale up the DC power controller to run a diesel-electric locomotive, and since then, hybrid drive has been common for railroad, ship and submarine propulsion.

These are all series hybrids, so called because the ICE drives the generator, which drives the electric motor, which drives the wheels. This arrangement works well in low-speed, high-torque applications because the electric motor produces maximum torque at zero revolutions per minute (rpm). Maximum cranking power is available to get the locomotive or the submarine moving, without the use of a complex, heavy clutch and transmission.

The series drive is less useful in high-speed cruise, because there’s an efficiency loss between the generator and motor—and a double efficiency loss if a battery sits in the electric flow between the generator and motor. In automobiles, that’s always the case. The driver may need more power, for quick acceleration or hill climbing, than the engine-generator combination can provide instantaneously — so you want some power in reserve, stored in the battery.

A car, however, is light and agile compared to a locomotive. A sophisticated lightweight transmission can be designed to bypass the electric motor at cruising speed and connect the ICE directly to the wheels. The result is a parallel hybrid system, where the ICE and the electric motor work one at a time or in tandem, depending on what’s most efficient for the driving situation. Excess power from the ICE is routed through the generator to keep the battery charged and ready to pitch in for bursts of acceleration. This is the system that runs most of today’s hybrid and plug-in hybrid cars, including all the hybrids from Toyota, Honda, Ford, Hyundai and BYD.

The exception is the Chevy Volt. In principle it’s a simple series hybrid like Pieper’s 1905 car — the battery runs the electric motor to drive the wheels through a slick continuously-variable transmission. The ICE never drives the wheels but rides along until needed to recharge the battery. The Volt, to be sure, uses 21st century integrated-circuit controls to make smooth, quiet power throughout the speed range.

Any proper hybrid does better in stop-and-go driving than a pure ICE, because it doesn’t idle when stopped and because it recovers energy through regenerative braking. So do you want a series or a parallel hybrid? In theory, the series hybrid should be less complex and more easily adaptable to a wide variety of auxiliary power plants, from diesels to Stirling heat engines. The Volt drive train will thus be the base for dozens of car and truck applications. But parallel hybrids are here right now and here to stay. So we’ll see.

Courtesy: Solar Today

ENERGY STORAGE INDIA 2014 CONCLUDES WITH BROAD CONSENSUS ON OPPORTUNITIES FOR STORAGE

Outlook is positive and opportunities abound in fast-growing market

The 2nd annual Energy Storage India Conference and Expo, hosted by the India Energy Storage Alliance (IESA) from December 3-5, 2014, in New Delhi, was a successful event that brought together more than 500 industry professionals and 65 speakers from 15+ countries. It was the largest such gathering ever held in India, and highlighted the many opportunities available in a fast-growing market.

Energy Storage India 2014 was attended by a diverse, business-focused group that included utilities, developers, energy storage OEMs, solution providers, Government of India ministries, regulatory and policy officials, commercial/industrial end users, and other industry stakeholders.

Dr. Rahul Walawalkar, Executive Director of IESA, states: “We expect the next five years will see a dramatic transformation towards decentralized energy solutions in India. ESI 2014 demonstrated the progress India has made over the past 12 months in creating a solid ecosystem for advanced energy storage, with the country poised to become a global hub for technology deployment as well as manufacturing”.

Dr. Walawalkar continued: “During the conference a broad cross-section of industry stakeholders came together to agree on the need for storage to meet various development goals for India. We also heard commitments from policy makers to develop policy framework, from R&D groups on the potential for cutting-edge research and from companies on setting up everything from incubation centers to full-scale manufacturing plants for advanced storage”.

The conference began on December 3rd with three workshops covering key topics (Energy Storage 101, Power Quality, Micro-grids), and a parallel “IRENA International Energy Storage Policy and Regulators” workshop. Subjects covered in workshops and the conference program included the full range of battery technologies, as well as other forms of energy storage including pumped hydro, compressed air and thermal.

In addition, the event focused on opportunities for advanced storage solutions in India including renewable integration, rural electrification, micro-grids, smart cities, utility and industrial applications, and transportation. Other sessions covered financing models, project development, incentives and subsidies, and manufacturing options, with special panels on “**Make in India**” and “**International Perspectives on Energy Storage**” that generated significant interest among delegates.

Some of the highlights brought out during the conference include:

- The energy storage market in India is expected to grow to an aggregate capacity of between 15 to 20 GW by 2020.
- Massive expansion of renewable energy installations over the next five years in India will drive the need for energy storage to manage variations in renewable energy and maintain grid stability.
- India’s “100 Smart Cities” initiative is a smart grid deployment program aimed at increasing urban grid reliability and accessibility and that can be supported by energy storage.
- Actions being taken by the Modi government should provide stimulus for the growth of the country’s energy storage industry.
- Ongoing innovations in energy storage technologies will lead to cost reductions over the next 5-10 years.

ESI is grateful to its supporters, sponsors, exhibitors and partners for their support and contributions in making this year’s event a success. These include the Ministry of New and Renewable Energy (MNRE) as Principal Supporter; Siemens as Gold Sponsor; AMCO SAFT, Dassault Systems, Ecoult, Exide, Sun Edison and S&C as Silver sponsors; and Aquion Energy, Hitachi Chemical, Hosen Corp and Regen Powertech as exhibitors, as well as 30+ key industry partners and 27 media partners.

Read more: http://www.pv-magazine.com/services/press-releases/details/beitrag/energy-storage-india-2014-concludes-with-broad-consensus-on-opportunities-for-storage_100017595/#ixzz3MzOej0Cx.

Engineering is a great profession. There is a satisfaction of watching a figment of the imagination emerge through the aid of science to a plan on paper. Then it moves to realization in stone or metal or energy. Then it brings homes to men or women. Then it elevates the standard of living and add to the comforts of life. This is the engineer’s high privilege. - HERBERT HOOVER

‘WE MUST HARVEST RENEWABLE ENERGY IN A DECENTRALIZED MANNER’

Leading experts deliberate on energy and environment for India in the context of Sustainable Development Goals at a workshop; TEDDY 2014-15 also released

New Delhi, March 31: Developing countries need to develop additional capabilities to achieve Sustainable Development Goals (SDGs). Means of implementation is important for mobilization of resources from various sources and for effective use of financing to promote sustainable development. These were some of the views expressed by eminent experts from the Government, research organizations and NGOs at a workshop “Energy and Environment in the Context of Sustainable Development Goals in India” held today. The workshop assumes significance as SDGs will be finalized and officially adopted at the upcoming United Nations General Assembly. The workshop is an output of a project on energy and environment under the DFID-TERI Partnership for Clean Energy Access and Improved Policies for Sustainable Development, and was organized by The Energy and Resources Institute (TERI).

The occasion also marked the release of the 29th edition of TEDDY 2014/15. TEDDY (TERI Energy & Environment Data Diary and Yearbook) is an annual publication brought out by TERI since 1986, which presents state of the art information on energy supply, energy demand and environment. Each edition of TEDDY contains India’s commercial energy balances that provide comprehensive information on energy flows within different sectors in the economy. TEDDY is a well referenced document and is often cited in government policy documents and scholarly articles. In the latest edition of TEDDY, a chapter on sustainable development goals, and another on sustainable energy has been included.

Speaking on the occasion, **Dr Leena Srivastava**, Acting Director-General, TERI, said:

“SDGs are now only focusing on developing countries, but are universal and recognize the roles of the developed countries. There is today recognition that developed nations should reduce their consumption patterns and improve their overall production efficiency. SDGs must be built on social, economic and growth pillars, and each goal is critically important for both ecological growth and social stability. We are trying to grapple on how to articulate these goals and bridge the gaps. This is important to plan allocations for each sector. Countries need to work under broad guidelines to evolve a roadmap to achieve these goals.”

Mr Chandrashekhar Dasgupta, Distinguished Fellow, TERI, and, Member, PM Council on Climate Change, said: “How does one differentiate between targets for developed and developing countries? Differentiation must be based on capability and responsibility. We still need specific goals to measure progress. We must not forget the centrality of energy and water issues to achieve SDGs. This is a timely workshop and we need to focus on the trinity of sustainable development, environmental sustainability and sustainable energy”.

Said **Mr Anil Jain**, Advisor-Energy, National Institution for Transforming India (NITI) Aayog: “The basic concern is that development must be sustainable. Sustainability is related to the issue of equity – with people, between nations and inter-generational equity. In light of increasing climatic events, water stress and decreased agricultural yields, we must ensure that sustainable development must be ingrained in our development pathways. Air pollution has a huge relevance for sustainable energy. Our National policies must be sensitive to international and regional policies.”

Dr P C Maithani, Director, Ministry of New and Renewable Energy, said: “According to the Census 2011, 45 per cent of our population still do not have access to electricity. Efforts must be made to integrate renewable energy to the grid. We are now beginning to export wind energy and have been making efforts to promote indigenous manufacture of renewable energy technologies. The task is gigantic and to bring about a transition, we need political will and governance mechanisms.”

Said **Mr Prabir Sengupta**, Distinguished Fellow, TERI: “TERI has done intense research on sustainability and climate change, and we need to redefine our energy sourcing by reducing our dependence on fossil fuels and invest more in renewables. TEDDY is the only comprehensive book in India, and we have decided to publish data in raw form to enable research professionals to learn and interpret data.”

Mr Prabhat Upadhyaya, PhD candidate, Linköping University, Sweden, said: “There has been a fragmentation of global governance because the driving principles are different for different countries. We need to align various sectors as they are interconnected. To address environmental and energy sustainability, we need drivers to bring about change in the local context”.

Said **Ms Lydia Powell**, Head, Centre for Resources Management, Observer Research Foundation: “Sustainability has become a much abused word; sustainability for what and for whom? What we want is to sustain the quality of life. We need to be realistic about the cost of renewable energy, as it is a complex issue and has wide ramifications.”

Ms Shailly Kedia, Fellow, TERI, said: “We need to develop a reporting framework as we are on track on some goals, but are off-track on a number of goals. Global environmental goals must be aligned more closely with the Rio Convention and other multilateral agreements. Still, air pollution goals are weak and we need proper data collection and monitoring network. It is not receiving the kind of attention it deserves.”

Ms Rinki Jain, Associate Fellow, TERI, said: “Significant efforts are needed to improve data collection methodologies. We need to bridge the identified gaps and implement statistical standards.”

The workshop comprised panel discussions on „Sustainable Development Goals in Context of India, “Sustainable Energy”, and “Environmental Sustainability”. Participants at the workshop highlighted the fact that coal and oil together account for 86 per cent of the total energy supply in India in 2011-12. Given the limited and unevenly distributed supply of non-renewable resources, it will become extremely difficult to meet India’s growing energy demand by relying on conventional energy alone. Harvesting renewable energy in a decentralized manner is one of the options to meet the challenges of providing modern energy services in India. Knowledge processes will also help mobilize governments, businesses, and civil society organizations around a shared set of sustainable development goals for our common future, they said.

About TERI

The Energy and Resources Institute (TERI) is an independent, not-for-profit research organization deeply committed to every aspect of energy, environment, and sustainable development. From providing environment-friendly solutions to rural energy problems, to helping shape the development of the Indian oil and gas sector; from tackling global climate change issues across many continents to enhancing forest conservation efforts among local communities; from advancing solutions to growing urban transportation and air pollution problems to promoting energy efficiency in Indian industries, the emphasis has always been on finding innovative solutions to make the world a better place to live in. All activities at TERI move from formulating local and national-level strategies to suggesting global solutions tackling critical energy and environment related issues.

INDIAN LED INDUSTRY SET TO TOUCH RS 21,600 Cr. BY 2020

Estimate follows govt’s decision to switch to LED for all street lamps and public space lighting

The market size of Indian **LED industry** may touch Rs 21,600 crore by 2020 on the back of government’s decision to switch to LED for all street lamps and public space lighting, an industry official said.

The Indian LED industry was pegged at Rs 1,925 crore out of the lighting industry’s aggregate turnover of Rs 13,000 crore in 2013.

As projected, the turnover of Indian **lighting industry** by 2020 will be Rs 35,000 crore and LED will account Rs 21,600 crore, which is significantly over 60 per cent of this total turnover, **Surya Roshni** Managing Director Raju Bista told PTI.

Bista pointed out that in the wake of continual Narendra Modi-led government’s support for the promotion of LED lighting, this market is expected to grow substantially.

The government has decided to switch to LED for all street lamps and public space lighting.

Moreover, the ‘**Make in India**’ initiative launched by Prime Minister **Narendra Modi** will provide a boost to the LED industry, he said and added that Surya has already commenced in-house production of indoor and outdoor LED products at its plants.

These include LED bulbs, down-lighters of various shapes and sizes as well as street lights.

The company’s **prime focus** is to educate and promote only sustainable energy efficiency and drive the LED segment forward.

Press Trust of India

If you don’t practice Electrical Safety, there can be electrifying results.

GUJARAT MAY GET INDIA'S FIRST OFFSHORE WIND POWER PROJECT

The country's first ever offshore *wind power project* is set to come up in Gujarat. While on one hand, the Central government is roping in public sector undertakings, on the other hand, *Suzlon* is conducting a techno-commercial feasibility study for offshore wind power project in Gujarat.

The Ministry of New and Renewable Energy (MNRE) has recently signed a memorandum of understanding (MoU) with a group of public sector undertakings and others to setup a joint venture company for an offshore wind power project in Gujarat. The consortium for the 100 Mw wind power plant project comprises of National Institute of Wind Energy (NIWE), and consortium of



partners consisting of National Thermal Power Corporation (NTPC), Power Grid Corporation of India Ltd (PGCIL), Indian Renewable Energy Development Agency (IREDA), Power Finance Corporation (PFC), Power Trading Corporation (PTC) and *Gujarat Power Corporation Ltd (GPCL)*.

On the other hand, Suzlon is planning to come up with a 300 Mw offshore wind power project on a pilot basis. "The central government is likely to come up with an integrated single window policy on offshore wind power generation. We are expecting the policy within a year, after which we can start work on the project. Currently, the techno-commercial feasibility study is on since we need wind data for the pilot project in Gujarat," said Tulsi Tanti, chairman of Suzlon Group.

According to Tanti, though on a pilot basis, the offshore wind power project by Suzlon, possibly the first in the country, is likely to come up in Gujarat within four years from the time of commencement of work.

Part of MRNE's initiatives towards offshore wind power development also include announcement of draft National Offshore Wind Energy Policy and preparation of draft Cabinet note on National Offshore Wind Energy Policy. Once promulgated, the proposed National Offshore Wind Energy Policy will provide a conducive environment for offshore wind energy.

In this, experts believe, Gujarat has natural advantage over other states in leveraging on its offshore wind power capabilities.

"Luckily, Gujarat has a long continental shelf over 50-60 per cent of its total coastline wherein the slope of the sea is gradual. This makes setting up of offshore wind power conducive. Also, south west winds come all over Gujarat from the Arabian Sea, thereby providing unhindered wind for at least six months. Hence, Gujarat has advantage over other states and the potential is huge for offshore wind power generation from Gujarat's coast," said Anil Kane, president of World Wind Energy Association and chairman of Indian Wind Energy Association.

However, Kane cited that power absorption may become an issue. "The state and central government will have to work on setting up power absorption infrastructure so that the wind power generated offshore is absorbed," he added.

As far as the PSU consortium is concerned, a subsidy for setting up of evacuation and transmission infrastructure of the offshore wind power to the main land has been proposed, besides provide financial support for carrying out studies such as wind resource assessment, Environment Impact Assessment (EIA), oceanographic survey and Bathymetric studies. Moreover, MNRE is also set to assist in obtaining clearances involved during the implementation of the project.

It needs to be mentioned here that globally around 7.5 Gw of offshore wind power projects have been installed in countries like China, UK, Denmark, Germany, Netherlands, Sweden, and Belgium.

SAFETY TIPS: *Electricity has the POWER to KILL.*

VECTOR SOLUTIONS



Vector solutions, a professional organization engaged in providing solutions for Power quality measurement and improvement and Harmonic filtering by using Electronicon make capacitors, detuned filters, Thyristor switching modules, Active Harmonic filter, Power factor controller and other range of products as a authorized channel partner of Electronicon, Germany.

Power Capacitors:

- oil filled / Gas Filled capacitors available from 380 V to 800 Volts
- Any Higher Ratings Also Can be Provided Against Specific Requirement
- One upon winding, which will provide more space for the circulating current as against Concentric winding.
- Less than 0.4 watts per Kvar losses in the Capacitors
- Light weight.
- Any mounting is possible (Horizontal and Vertical)
- 1.50 Lac working hrs Life



Thyristors:

- Switches at Zero Voltage cross over .
- Ratings available from 10 Kvar to 100 Kvar single units (Others only up to 50 Kvar)
- Antiresonance feature in TSM over and above 75 Kvar.
- TSM Over and above 75 Kvar are provided with Fan for cooling



Reactors:

- Up to 10 Kvar Copper Wound
- Made out of CRGO Material
- Low losses.
- Highest linearity 200%
- Low weight.
- Above 15 Kvar Al wound reactor.



Active Harmonic Filter:

- Available Rating From 30 Amps to 600 Amps
- Available For 3 Phase 3 Wire & 3 Phase 4 Wire System
- Powerful DSP- Better Control over The Entire Load Cycle.
- Unbalance Correction
- Flicker Correction



Power Factor Controller:

- User Friendly Controller
- Available with Relay Output
- Available with Transistor Output
- Available From 4 Steps to 14 Steps



Why Vector Solutions

- Authorised Channel Partner For Electronicon in Tamil Nadu
- Ready Stock
- Prompt Service
- Cost Effective Solutions
- Array Of Products & Services Under One Roof

Other Range of Products:

Authorised Distributors for Secure Meters, Newtek Current Transformers, Metrel Power Quality Analysers, Lapp Cables, Craftech Indication Lamps, Elmex Terminal block & connectors,

Call Now - R.C. SAIRAM SURESH Mobile : 96772 56822 & E.NATARAJAN Mobile : 97911 62811
Email Now : sairamuresh.vector@gmail.com, natarajan.vector@gmail.com



VECTOR SOLUTIONS

No.1, 12 th Street, 1st Floor, K.K Road Venkatapuram, Ambattur Chennai - 600 053.
Phone No: 044-42105868, Email: vectorsolutions13@gmail.com

ABB BETTER WORLD SERIES

5 ways energy efficiency is changing the world

Energy efficiency' is a term heard in almost every discussion on sustainable development and climate change. But what does it involve? *Vaidehi Shah* explores some solutions with the greatest potential to reduce global emissions.

Energy efficiency is a term that is ubiquitous in global sustainability efforts and has been identified by the International Energy Agency (IEA) as "the greatest potential" to reduce greenhouse gas emissions. It also has a direct link to economic growth - Swiss power and automation giant ABB notes that the most efficient economies generate almost 16 times more gross domestic product (GDP) with the same amount of energy than the least efficient.

Behind the scenes, many companies worldwide are developing solutions that extract more value from each unit of energy. Despite the potential of energy efficiency to mitigate climate change, "there is a large gulf between what is being done and what could be done" in the area, says ABB, which has over many decades developed a wide range of solutions to reduce energy consumption and improve productivity. Here's a closer look at how the range of applications offered by the company helps companies and governments around the world achieve the holy grail of energy efficiency.

1. It's making energy smarter

The power generation industry is the world's largest energy consumer, and some fuel sources and technologies can be extremely inefficient. A plant's electrical system can consume between *seven and 15 per cent* of all the energy it produces, taking away from its revenues and profitability.

However, software and hardware interventions can make these power plants more energy efficient and improve their overall performance.

ABB has been manufacturing motors and generators used in power plants for more than three decades, and has the systems and expertise to ensure that these fixtures operate optimally.

For example, the firm's Symphony Plus system - a combination of software, electrical devices and communication networks - helps industries reduce power consumption through better monitoring and control. Power and water plants maximise their efficiency by automating the various complex processes that take place within each facility.

In Singapore, the Senoko Power Station in 2013 commissioned the installation of the Symphony Plus System, a move that the Senoko power plant's head of instrumentation and control, Lim Leong Chuan, said would enable plant workers to spot any inefficiencies or malfunctions and correct them quickly.

2. It's making your energy cheaper and cleaner

The process of generating power to users typically result in electricity losses of about 9 per cent globally. Technology innovations, such as high-voltage direct current (HVDC) systems could reduce these losses.

Power systems have historically transmitted electricity using alternating currents (AC), where the current flowing through the network alternates in direction at a predetermined frequency. While AC power was chosen over

direct current (DC) - where current flows in a single direction - because it was seen as easier to interrupt or change voltage, it is less suitable than DC for carrying electricity over long distances.

Not only does electricity transmission via direct current have lower losses than AC, but AC cable transmission also has a maximum distance of 50 to 100 kilometres.

Enter HVDC transmission, which can carry electricity over long distances with minimal power losses. ABB developed the world's first commercial HVDC installation in the 1950s, and has since delivered more than 70 HVDC projects worldwide.

HVDC helps global cities such as Los Angeles, Sao Paulo, Shanghai and Delhi deliver electricity from far-away sources to urban centres, and is particularly suitable to



support the growth of renewable energy sources such as wind and solar, which can be located far away from power utilities.

In 2015, for example, ABB launched a \$1 billion HVDC transmission link that was commissioned in 2011 by the Dutch-German grid operators TenneT. The link transports energy from wind farms in the North Sea to the German national grid, and has a capacity of over 900 megawatts.

The BorWin1 HVDC Light System, which will transport power from a wind farm 130km off the German coast in the North Sea to an onshore power station at Diele, 75km from the German coast. Image: ABB

The technology is a key component in the future energy system based on renewable energy sources, such as wind and solar power which are often both volatile and remotely located, says ABB.

3. It's keeping your oceans clean

When ships are in harbour, using on-board diesel generators to maintain power can result in air and water pollution, noise, and vibration, resulting in an unpleasant experience for those on board and in the surrounding community.

The amount of fuel burned by ships when they are in port can result in 900 million metric tonnes of annual carbon dioxide emissions, equivalent to 220 coal-fired plants, ABB estimates.

While it has traditionally been a challenge for ports to supply electricity directly to ships due to differing power frequency requirements of ships from different countries, ABB's shore-to-ship power supply technology allows any ship to be connected to the power grid, regardless of whether their on-board power, voltage, and frequency requirements match those of the port.

Not only does drawing power directly from the port help ships reduce the emissions from their diesel generators, it also helps them avoid potentially costly penalties for pollution imposed by most countries today. ABB estimates that hooking up just one cruise ship to the port could save \$750,000 in operational costs, and avoid carbon emissions equivalent to 2,500 cars.

The world's first commercial shore-to-ship power system was installed in Sweden's Gothenburg port in 2000, which earned environmental responsibility accolades from the European Union and maritime journal Lloyd's List. Shore-to-ship power connections have been implemented in approximately two dozen port terminals worldwide since 2000, including in Rotterdam, Holland and Ystad in southern Sweden. They are also found on over 100 ships ranging from cruise vessels to oil tankers and container ships.

4. Your favourite snack could be made by a robot – in the dark

Food and beverage companies are increasingly turning to robotics technology to help them meet uncompromising expectations of hygiene and safety while keeping production costs low.

At UK-based Honey top Specialty Foods, for example, spider-like robots have been plucking pancakes off conveyor belts and packaging them since 2011 – a system that paid for itself in less than a year thanks to cost savings arising from less energy use.

Not only does robotics technology ensure that no human hand touches the pancakes except those of consumers, it also speeds up production, and reduces labour costs.

These solutions are improving productivity as well as workplace health and safety across a range of consumer goods sectors, including frozen foods, ice creams, medical products, and cosmetics.

Lim Say Leong, assistant vice president of marketing, ABB, also observes that “unlike humans, robots do not need lighting or air conditioning to operate”. Cutting back on these areas of energy use results in even more indirect savings, he adds.

This is just the tip of the iceberg of how robotics can help companies improve their resource efficiency. With over 200,000 robots worldwide deployed across a range of industries, including construction, manufacturing, and health care among others, companies worldwide are set operate in a faster, cheaper, safer, and more sustainable way.

5. It's cutting your energy bills by more than half

Buildings guzzle about 40 per cent of the energy consumed in most countries, and achieving a comfortable, well-lit environment for occupants while reducing energy usage is always a challenge for building managers.

Building control systems are emerging as the key to raising energy efficiency levels. They allow building owners to control and monitor air conditioning, lighting, and various electrical appliances without much extra effort or compromises on comfort.

Motion detectors, for example, can ensure that energy is only used when occupants are present, while light control that assesses outdoor light can also minimise the use of daytime lighting.

These techniques can slash lighting costs by up to 80 per cent, and heating and ventilation costs by up to 45 per cent, says the Association of the German Electrical Industry.

ABB has developed an intelligent building control system, the *ABB i-bus KNX*, based on a global open standard called KNX, which has been installed in *thousands of buildings in over 60 countries worldwide*, including Singapore's National Library building, India's Indira Gandhi National Airport, and the ANZ Tower in Sydney, Australia.

The system also helped the Museum of Modern Art in Rovereto, Italy, save about \$112,000 in just a year by cutting energy use by 28 per cent, and helped Dubai's Etihad Towers buildings achieve 30 per cent energy savings.

ABB's Lim notes that in addition to building managers, "chief financial officers of companies should also pay attention to the smart building system to the control panel – energy efficiency can help companies reduce costs significantly".

These, and many other energy efficiency technologies, work unseen in buildings, industrial facilities, transport systems and nationwide power infrastructure to help power growth while using less, and cleaner energy.

These technologies could help deliver half the cuts in emissions needed to slow global warming over the next 25 years, says ABB. They could also help Singapore and other similar countries to stay cost-effective and make sustainable progress, says Lim.

"We need to implement more 'behind the scenes' technologies to improve energy efficiency and industrial productivity," he says



Vaidehi Shah has worked in Singapore's sustainability sector since 2008, in non-profit and government organisations. She has worked in various fields including corporate communications, policy research, and project management, and has overseen initiatives such as the Asian Environmental Journalism Awards 2012 and 2013, a research paper on reducing plastic bag use in Singapore, and a quarterly environmental newsletter.

Vaidehi Shah Correspondent – Eco Business
Courtesy: Eco Business

FAME

India scheme- 'Faster Adoption and Manufacturing of Hybrid and Electric vehicles in India'

In a bid to promote green vehicles in India, the government recently launched the FAME India scheme- 'Faster Adoption and Manufacturing of Hybrid and Electric vehicles in India' - as a part of the National Electric Mobility Mission Plan. Under the scheme, the government will offer incentives on hybrid and electric vehicles; of up to Rs. 29,000 for two-wheelers and Rs. 1.38 lakh for cars. The government will spend Rs. 795 crore in the first 2 fiscal years under this scheme.



Starting with metropolitan cities, the scheme will be launched in all major and smart cities across the country. Under the scheme's purview, battery-run motorcycles and scooters will be eligible for incentives in the price range of Rs. 1,800 to Rs. 29,000. Similarly, one can demand incentive in the range of Rs. 13,000 to Rs. 1.38 lakh if he/she buys an electric or hybrid car. For three-wheelers and light commercial vehicles, the incentives are in the range of Rs. 3,000 to Rs. 61,000 and Rs. 17,000 to Rs. 1.87 lakh, respectively. Whereas, for buses it ranges from Rs. 34 lakh to Rs. 66 lakh.

"We are starting the scheme in metropolitan cities. Eventually the scheme will be launched in Smart Cities and all major cities across the country," Union Heavy Industries Minister Anant Geete said.

At the launch of the scheme, the government officials also revealed that several leading carmakers, including Maruti Suzuki India and Tata Motors, will soon bring in few such vehicles in the country.

Talking about the country's largest carmaker, Maruti Suzuki India, it is ready with a hybrid version of the Swift - the Range Extender - that was showcased at the event. The same vehicle was earlier showcased at the 2014 Delhi Auto Expo.

CV Raman, executive director (engineering) at Maruti Suzuki told NDTV that the company will develop its hybrid models commercially only after "getting further clarity on key aspects, including technology development fund, charging infrastructure and demand incentive."

By: Vikas Yogi / NDTV Auto

SOLAR IMPULSE II - UPDATE:

Si2 has been stuck in Chongqing since March 31st because of poor weather conditions. High altitude clouds, limiting the aircraft's energy collection, and crosswinds, that conflict with the airplane's itinerary, have led the Mission Control Center to postpone departure to Tuesday April 14th at the earliest.

APRIL 15TH - FLIGHT UPDATE

Unfortunately, we have decided to postpone the flight planned for tomorrow morning. The weather window allowing a landing at Nanjing is too small and risky.



APRIL 22ND - FLIGHT UPDATE

The plane landed in Nanjing in the northeast of China at 23:30 local time (14:30 BST) after a journey of more than 15 hours and 740 miles (1,190km) from Chongqing in the southwest of the country on 21st April 2015. The plane will go through servicing for the next 10 days before it prepares for the daunting five-day crossing of the Pacific Ocean to Hawaii.

MAY 6TH - FLIGHT UPDATE

He plans to depart Nanjing for Hawaii as soon as weather conditions permit from this weekend and told the South China Morning Post that he was making the final mental and physical preparations for the risky flight.

That part of the flight will see him spend at least five days alone in a cockpit of just 3.8 cubic metres - with eight 20-minute power naps the most rest he expect each day.

The earliest window of good weather for the departure is Saturday, but weather will dictate the exact time and flight path as the super-light plane is susceptible to winds and needs sunshine to recharge its batteries every day.

It flies at an altitude of up to 9,000 metres during the day and descends to 1,500 metres at night to conserve energy, meaning it should ideally pass through clouds at night and be in a sunny area in the early morning to collect energy, Borschberg said.

The two pilots are planning to alternate on make five more flights after Hawaii to complete the 35,000km round-the-world trip and return to Abu Dhabi.

The Solar Impulse team would like to thank everyone who helped to prepare this operation, especially all the Chinese authorities, the Civil Aviation Authority of China (CAAC) and ATC centers who gave us full flexibility for our planning.

THE THREE PRINCIPLES OF SUSTAINABLE HOME COOLING

There are three simple principles for keeping a home cool in summer without inflating your carbon footprint, according to architect Steffen Welsch who will be one of the experts giving advice at the Alternative Technology Association's Speed Date a Sustainable Expert event in Melbourne this weekend.

First, prevent hot air from entering; second, soak up any heat that does enter within the interior; and third, move air around inside to increase comfort. And most are achievable in an existing detached home or apartment, even if it's a rental.

Keeping the heat out

To prevent hot air entering is partly a matter of sealing the building envelope, but also preventing sun hitting the windows and other glazing, Welsch told *The Fifth Estate*. The simple solution is vertical blinds installed on the exterior of windows.

Conventional interior design dictates blinds hung inside to block sun, but Welsch says while the blinds might block the glare, by the time the sun enters through the glass they do not block the heat.

Vertical blinds are also more efficient at shading glass than horizontal ones, and vertical blinds reduce the effect of radiant heat on the building, he says.

Another easy cooling measure those in freestanding homes can implement is creating areas outside the house that soak up heat, such as garden beds and other vegetation, or a timber deck area that will absorb heat instead of paving, which radiates heat.

For an apartment, where many have only an outdoor terrace or balcony, plants in pots, timber decking placed over ceramic tiles or concrete, or even a large timber outdoor table can all help add shade and soak up the sun, reducing the amount of heat the outdoor space radiates.

Soak it up

Welsch says the principle of interior elements that will absorb heat is "underrated and often completely overlooked". The basic principle involves having thermal mass inside, elements such as stone or concrete floors that will absorb heat from the air, or reverse brick veneer, where the brickwork is on the inside. Exposed solid plaster also works well, he says.

Timber floors generally perform better than carpeted floors for absorbing heat, and in homes where there are struts under a timber floor, it is possible to retrofit under floor insulation.

Options for insulation include the new "phase change" materials that are only a few millimetres thick but deliver the insulation benefits of a 200mm brick wall. They work by absorbing heat, which changes the state of the material from solid to liquid when it is hot, and from liquid back to solid when it cools.

These are still quite expensive, however, due to the current small market share. Welsch does think the price will, however, go down.

Indoor breezes

The third principle of moving air about can be achieved through mechanical measures such as ceiling fans and through strategic window placement.

"When the air moves, then you feel more comfortable at higher temperatures," Welsch says. Fans also assist with airing a house out when the cooler evening change hits.

"You also need to check the window openings are in the right place. For example, in Melbourne the cool change comes from the south west, so a low window should go there, and a high window in the north-east corner."

The cool air entering shifts the hot air out the higher window, but window placement is another thing Welsch says is often not being properly considered. Generally, diagonally opposite windows will work better for cooling and ventilation than multiple windows on the same side of a room – a good thing to keep in mind when renovating, extending or planning to build.

Clerestory windows set up high under the eaves are also effective for ventilation and cooling. They rely on the natural stack effect of air at different temperatures. They can be manually operated, or it is possible to install automated window opening, which is particularly effective when combined with a temperature sensor control. These are not expensive technologies at the domestic scale – Welsch says an automated window opener can cost between \$60 and \$80, and a temperature sensor control for about \$30.

Electrical Safety is No Accident

More cool, green ideas

Even though sealing the building well is part of managing heat gain in summer and heat loss in winter, some form of ventilation is essential for occupant health. Having well-sealed homes also means it becomes more important to be careful in the choice of interior finishes and materials, including furnishings, to minimise the level of volatile organic compounds and other nasties.

Other things those looking to build or renovate would want to consider are double glazing, insulation and zoning controls for any ducted air-conditioning system. These are, however, best avoided altogether, Welsh says.

Ideally, in terms of environmental impact, air-conditioning should be viewed only as a back-up system, not the main solution. If there is no shading or other measures, a refrigerated ducted system is “questionable” in terms of carbon footprint.

Courtesy: Eco Business

VELOGICAL SHRINKS THE RIM DRIVE TO “WORLD’S LIGHTEST” E-BIKE DRIVE

The Velogical Velospeeder rear rim motor system

Friction drives like the Rubbee provide a lighter, simpler option for transforming a regular bicycle into an e-bike. Velogical’s all-new Velospeeder makes the friction drive even lighter. The compact e-drive solution weighs under 4 lb and allows for seamless switching between e-assist and manual riding. The company claims it’s the lightest and smallest bicycle e-drive (soon-to-be) available.

Cologne-based Velogical builds rim dynamos for powering bike lights, and at first glance, that’s what the Velospeeder looks like.



However, it’s actually a sized-down e-drive that offers up to 600 watts of power and 29.5 lb.ft (40 Nm) of torque. At 3.5 lb (1.6 kg) for the entire package, it comes in much lighter than other e-drive kits. The current iteration uses a 92-Wh lithium-polymer battery that provides up to around 12.4 miles (20 km) of e-assist. Velogical says that the battery is light enough to carry a spare and easy to swap.

The dual Velospeeder motors mount to the seat stays of a traditional bicycle frame, where they transfer power to the rear rim by way of their polyurethane rings. A toothless drive system on a smooth metal rim sounds ripe for slippage, but Velogical says that the dual swing-axle design of the drive keeps the motors in optimal contact with the rim at all times. In this way, the Velospeeder is able to efficiently apply pressure and power the wheel at start and slow speeds, but also decrease pressure during faster speeds, preventing unwanted braking and wear effects.

One advantage of a lightweight e-drive is that it doesn’t add a brick-ton of weight to the bike, freeing up easier manual pedaling. The most recent Velospeeder design makes it easy to switch between manual and electric-assist riding. When the rider powers the motors on, they automatically adjust to contact the rim at the same time. When the rider shuts the motors off, they adjust off the rim, freeing up natural wheel spin.

The Velospeeder is in the prototype stages and was revealed at the Spezialradmesse last month. Velogical has put 4,000 km (2,485 miles) on its Velospeeder-equipped test bike, in a variety of weather conditions, and reports that there is no noticeable wear on the rim. The company plans to continue testing and optimizing the system before moving to start distribution next year. It will be selling the drive to bicycle manufacturers for installation on new models and bike shops for retrofitting, but it does not plan to sell directly to consumers as it does with its dynamo.

Velogical doesn’t have a polished video yet, but the short clip shows how the Velospeeder applies torque to the rim and shuts off to allow natural spin. Velogical told us that one of its next steps will be working on the noise level.

Loose Wires cause Fires

AN ECO TOWN UK

An eco-town described as the UK's "most sustainable development" is moving closer to being occupied. The first residents are expected to move into North West Bicester later this year. Planning permission has also just been granted for up to 2,600 homes in the next stage of the project.

North West Bicester (pronounced "Bister") is one of four designated eco-towns in the UK announced by the government in 2007. The aim is to create a town that is good for the environment, good for the economy and a nice place to live.



It is also one of a handful of One Planet communities around the world. The One Planet scheme was set up by sustainability charity BioRegional. It aims to find ways for people and societies to reduce their level of consumption to an extent that is sustainable based on the amount of resources that the planet can provide.

In addition to homes that are highly sustainable, North West Bicester will offer a mix of affordable housing. Homes will be built to a minimum standard of code level 4 for Sustainable Homes and BREEAM excellence, with energy monitoring systems. They will also be future-proofed with climate change adaptation in mind.

Primary schools will be located within 800 m (2,625 ft) of all homes in the town, and jobs will be created within a sustainable travel distance. Non-car use will be encouraged, as will the use of electric vehicles where required. Town residents will benefit from specially-designed cycle and pedestrian routes, a bus service within 400 m (1,312 ft) of every home, charging points for electric vehicles and an electric car club.

A minimum level of 40 percent public and private green space is to be maintained throughout North West Bicester. There will be a focus on local food production and an aim of attaining a net gain in local bio-diversity.

The first phase of the town being constructed is called Exemplar. Once completed, it will have 393 zero carbon homes and, according to project lead A2Dominion, will be the UK's first true zero carbon community. Among the amenities in Exemplar will be a primary school, community center, eco-pub and an eco-business and retail center.

Each home in Exemplar has been designed to remain warm in winter, but not to overheat in the summer. A combined heat and power plant will provide heat and hot water to the houses, whilst solar arrays averaging 34 sq m (366 sq ft) will be fitted to every property. This is said to be the UK's largest residential solar array in total, capable of powering 550 homes with excess power fed back into the national grid.

The recent planning approval for new homes is for an area adjoining the Exemplar site, which will be the next major phase of the project. Of the homes built here, 30 percent will be affordable, including extra care apartments for the elderly. A new primary school with playing fields, a nursery and a sports pitch with a pavilion will also be built.

The plan also features space for a network of allotments, a country park, play areas, a community farm and a woodland burial ground. The area will have its own center with a convenience store, cafe, restaurant and shops, a public square and community hall. Other amenities will include an energy center, a GP practice, business and office provision and a place of worship.

Residents are expected to begin moving into Exemplar later this year, with the phase due for completion in 2018. A2Dominion plans to develop North West Bicester over the next 25-30 years. When complete, the town will have up to 6,000 highly energy efficient new homes.

*You've done it before and you can do it now. See the positive possibilities.
Redirect the substantial energy of your frustration and turn it into
positive, effective, unstoppable determination – **RALPH MARSTON***

**Releasing of Revised Edition of
"GUIDELINES ON ELECTRICAL INSTALLATION
FOR PRACTISING CONTRACTORS" – 25.03.2015 – Part II**



Mr. P. Suyambu, Treasurer, TNEIEA
honouring **Er. S. Appavoo**, CEIG

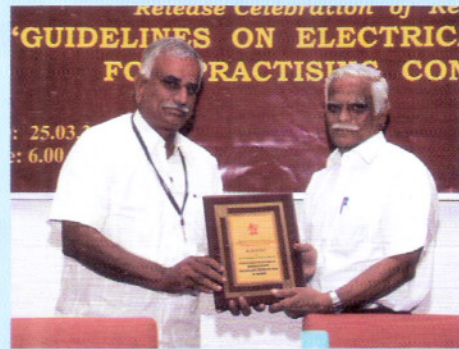

Mr. S. Ponnambalanathan, Madurai Vice President, TNEIEA
honouring **Mr. T.M. Bhikkaji**, Ex-Secretary, TNEIEA



Mr. B. Paalani Kumar, Chennai Vice President, TNEIEA honouring
Mr. A. Shanmuga Velayutham, Proprietor, IPL Products



Mr. S. Manivannan, Salem Vice President, TNEIEA
honouring **Er. D. Karthikeyan**, Electrical Inspector



Mr. S.D. Poongundran, Cuddalore Vice President, TNEIEA
honouring **Er. D. Selvaraj**, Electrical Inspector



Mr. D. Santhanam, Member, TNEIEA honouring
Er. M. Kamal Basha, Retd. CEIG



Mr. S. Mahadevan, NEWSLETTER Advisor honouring
Er. L.A. Srinivasan, Retd. CEIG



Mr. M. Murugan, Member, TNEIEA honouring
Er. M. Vedachalam, Retd. Electrical Inspector



Mr. M. Balamurugan, Committee Member, TNEIEA
honouring **Mr. N. Kasi Viswanathan**, Retd. Electrical Inspector



Mr. S. Krishnamoorthy, Member, TNEIEA
honouring **Er. N. Hema**, Electrical Inspector



Mr. S. Jagathish, Committee Member, TNEIEA honouring
Er. R. Sivakumar, Asst. Electrical Inspector (Technical)



Mr. G.M. Vishnu Ram, Committee Member, TNEIEA
honouring **Er. M. Sakthivel**, Asst. Electrical Inspector



Mr. P. Suyambu, Treasurer, TNEIEA honouring
Er. G. Sathes Kumar, Asst. Electrical Inspector (Technical)



Mr. K. Kannan, Secretary, TNEIEA honouring
Er. B. Palanisamy, Asst. Electrical Inspector (Technical)



Mr. P. Suyambu, Treasurer, TNEIEA honouring
Mr. M. Murugan, Jr. Electrical Inspector



Mr. N. Vasu, Vellore Vice President, TNEIEA honouring
Er. S. Govindaswamy, Retd. Electrical Inspector

OSRAM DELIVERS NEW IR LED FOR BIOMETRIC ID APPLICATIONS

Iris-scanning technology promises to be a hack-resistant method to protect access to mobile devices including smartphones and tablets, and IR LED technology will enable such biometric applications.

Osram Opto Semiconductors has announced the IR Oslux SFH 4780S infrared (IR) LED centered at the 810-nm wavelength. The LED specifically targets biometric identification (ID) applications. Specifically, the new LED can be used for iris scanning to gate access to devices such as smartphones and tablets, or to secure financial or confidential transactions.

IR LEDs, or what Osram refers to as IREDS, are being used in a broad array of applications in mobile device, consumer electronic, security, and life science applications. LED manufacturers that offer IR LEDs are able to leverage LED advancements being driven for solid-state lighting (SSL) and realize benefits in specialty IR LEDs in terms of size, footprint, performance, and efficiency.

For example, Osram announced an LED earlier this year that could enable mobile phones to operate as a living room remote control, and a low-profile package is key to the application. IR LEDs are also one option for implementing touchscreen technology.

In the latest announcement, Osram is addressing a key security concern for consumers. Presently, the need to protect access to portable devices and the data stored on those devices is paramount. Moreover, consumers use such devices to perform many types of financial and other transactions that need a security layer. Passwords are far from perfect and strong passwords are inconvenient. Fingerprint-recognition technology is broadly deployed, but had been proven vulnerable in some cases. Iris scanning offers the potential advantages of simple usage for consumers and more robust protection.

In a typical iris-scanning implementation, a mobile device would use an IR LED to illuminate the eye, and the camera already integrated in the device would capture the iris image for identification. The process could be quick and tough to compromise for someone trying to improperly access a device or perform a secured act such as a financial transaction.

The new LED offers the performance and footprint needed in such an application. The product is the first in the Osram portfolio at the 810-nm wavelength that can yield high-contrast images of irises of any colour with relatively low illumination levels. The package is only 2.4-mm high, enabling use in most any mobile device. Moreover, the design delivers high intensity with a narrow emission angle.

The emission angle is $\pm 10^\circ$ and is achieved via a primary lens on the package that is optically matched to the internal reflector. At 1A, the LED outputs radiant intensity of 2900 mW/sr (milliwatts per steradian). Developers can drive the LED up to 2A in pulsed mode.

Of course, developers must follow appropriate guidelines to ensure safety when working with an IR LED and directing the output into the eye. Osram has an application note that covers the usage and the relevant eye safety standards.

*Courtesy: Maury Wright, Editor in Chief, LEDs Magazine and Illumination in Focus
Published on: December 15, 2014*



***Electrical Equipment that Smokes, Sparks, Shocks, Smells,
Blows a Fuse, or Trips a Circuit can KILL.***

POWERING ENGINEERS THROUGH TRAINING – L & T

The Switchgear Training Centres have been set up with an aim to impart knowledge related to the selection, application, installation, operation and maintenance of Low and Medium Voltage switchgear, Industrial and Building Automation products. Depending on the kind of professional enrolled and course content, the programmes involve a blend of classroom sessions, practical training and case studies. These programmes offer participants an invaluable experience, thereby promoting good engineering and management practices among Electrical and Automation professionals, panel builders, project professionals and electrical consultants.

CODE	PROGRAMME NAME	DAYS	MAY 2015	JUN 2015	JUL 2015	FEES Rs.
LT01	SELECTION OF LV SWITCHGEAR AND APPLICATIONS Need for switchgear, LV switchgear terminologies, product standards, fault current calculation for LV system, Selection & application of low voltage switchgears - like contactors, thermal overload relays, motor starters.	5		1-5		14000
LT02	BEST MAINTENANCE PRACTICES IN LV SWITCHGEAR Safety & good maintenance practices, complete hands-on workshop sessions on testing, troubleshooting & maintenance of low voltage switchgear.	5	4-8		6-10	12500
LT03	BREAKER MAINTENANCE WORKSHOP - C POWER ACB Thorough hands-on training on C-Power range of Air Circuit Breakers, testing, setting & programming of various types of ACB microprocessor based protection releases like SR-71/SR21i.	3	18-20		20-22	6750
LT04	BREAKER MAINTENANCE WORKSHOP - U POWER OMEGA ACB - Complete hands-on training on U-Power Omega range of air circuit breakers. Including pole assembly replacement, Fixing & testing of various accessories. Testing, setting & programming of various types of microprocessor based releases.	2	21-22		23-24	4500
LT05	SWITCHBOARD ELECTRICAL DESIGN - Introduction to various standards for LV switchboard assembly including IEC 61439, types of panels, forms of separation, fault current calculations as applicable to low voltage switchgear, bus bar selection & design.	3	25-27			10000
LT06	POWER DISTRIBUTION IN BUILDINGS - Design parameters relevant to large buildings. Procedure for load estimation; sizing of transformers and DG sets. Sizing of Low Voltage switchgears.	3			1-3	10000
LT07	ELECTRICAL SAFETY - Basics – Safety, Importance of Safety, Electrical Safety, Types of Hazards, Fire, Shock, Effects of Fire and Shock, Safety in Residences, Safety in Industrial and Commercial premises	1				2500
LT08	SELECTION & APPLICATION OF DRIVES - Basics of LV motors, inverter duty motor, basics of LV AC VFDs, selection & application of AC VFDs, wiring diagram, parameter setting, salient features, energy conservation with AC VFDs, VFD vs soft starter. Classroom sessions supported by workshop demonstrations.	3				10000
LT09	REACTIVE POWER & HARMONICS MITIGATION - What is PF, types of LV capacitors, selection criteria, power factor improvement - concepts, methods & advantages, APFC panels, dynamic compensation.	2			9-10	6750
LT10	INTRODUCTION TO MEDIUM VOLTAGE SWITCHGEAR Selection & application of vacuum circuit breaker, specification of vacuum circuit breaker, fault current calculation, vacuum vs SF6 as a medium of CB.	2		11-12		6750
LT11	INDUSTRIAL PROTECTION WITH NUMERICAL RELAYS Introduction to protective relaying, terminologies, ANSI codes, CTs, PTs, Fault current calculations, relay co-ordination, feeder protection, motor protection, transformer protection, generator protection.	4		1-4		12500

CODE	PROGRAMME NAME	DAYS	MAY 2015	JUN 2015	JUL 2015	FEES Rs.
LT12	CONSERVATION & MANAGEMENT OF ELECTRICAL ENERGY - Importance of energy conservation & management, fundamental concepts of ECM, terminologies, software, energy efficient technologies in electrical installations, Energy Conservation Act, ECBC, etc. including some case studies.	2		24-25		6750
LT13	REQUIREMENT OF SYSTEM & EQUIPMENT EARTHING Need & purpose of earthing, various types & methods of earthing, selection of earthing system, system & equipment earthing, sizing of earth conductors, generator earthing, transformer earthing, earthing of sensitive electronic equipment	2		22-23		8000
LT14	INTRODUCTION TO INDUSTRIAL ELECTRICAL SYSTEMS Overview of Indian power system, typical industrial electric power distribution scheme, classroom sessions with workshop demonstrations giving exposure to a wide range of low voltage switchgear like contactors.	3	18-20	8-10, 15-17	13-15, 27-29	3000
LT15	FIRE DETECTION & SECURITY SOLUTIONS - Basics of Fire Alarm System, Conventional & Addressable FAS, Field devices, Panels & Software, Design / BOQ from Floor plans.	1	4			3500
LT16	BUILDING MANAGEMENT & ENERGY MANAGEMENT SYSTEMS - Basics of BMS, Components of BMS, Input & output devices, Controllers & Software, Installation & Commissioning, Energy Saving and Green building certification through BMS, Basics of Energy management, hardware and software features.	1	5			3500
LT17	SELECTION, PROTECTION & MAINTENANCE OF TRANSFORMER - Selection, Classification, Operation of Power and Distribution transformer, Vector groups, Transformer protections, Routine tests for transformer, Testing of transformer oil, Transformer maintenance, Earthing of transformer, relevant IS/IEC standards.	2				6750
LT18	INDUSTRIAL ELECTRICIAN TRAINING PROGRAMME Safety & good maintenance practices, hands-on workshop sessions on testing, troubleshooting & maintenance of low voltage switchgear such as contactors, overload relays, motor starters, switch disconnecter fuse, good termination practices	2			29-30	2000
LT19	ELECTRICIAN TRAINING PROGRAMME FOR RESIDENTIAL BUILDINGS - Basics of electricity, Selection of MCB, ELCB, domestic Switches, Wires and accessories e.g. Time switch, Introduction to Distribution boards, wiring demo staircase, godown lighting etc	1			31	1000
LT20	SWITCHGEAR SELECTION - MOTOR CONTROL CENTRE (MCC) - Motor control and protection techniques, Selection of Controlgear product range includes Contactor, O/L Relay, starter - Type-2 coordination	2	11-12		14-15	5500
LT21	SWITCHGEAR SELECTION - POWER CONTROL CENTRE (PCC) - LV Power distribution, Latest trends and selection of ACB, MCCB, SDF, Changeover and related accessories.	2	13-14		16-17	5500
LT22	DESIGN OF CONTROL CIRCUITS - Control Circuits & Schemes Fundamental Graphical Symbols & Nomenclatures of Various Components, Guidelines for Control Circuit Diagram.	2				6750

For more information about the Training Calendar and programmes.

Contact:- **Coonor** Larsen & Toubro Limited Switchgear Training Centre, Ooty-Coonor Main Road Yellanahalli P.O., The Nilgiris - 643 243 Tel. : 0423 251 7107 Fax : 0423 251 7158 E-mail: stc-coonor@Lntebg.com.

Equipped with his five senses, man explores the universe around him and calls the adventure Science.
- EDWIN POWELL HUBBLE, *The Nature of Science*, 1954

NEW YORK TO BUILD WORLD'S MOST POWERFUL SMART ENERGY LAB

The New York Power Authority and SUNY Polytechnic Institute will partner to build the *world's largest research and development facility* focused on energy technology innovation.

New York State has goals of eliminating electricity peaks, enabling distributed energy resources and incorporating more large-scale renewables as part of its *Reforming the Energy Vision proposal*.

The yet-to-be-built facility, the Advanced Grid Innovation Laboratory for Energy (AGILE), will allow the New York Power Authority, distribution utilities and private companies to test everything from sensors on the grid and automation technology to novel power electronics and cybersecurity across the entire power grid.



“This is new and innovative and will allow New York state to lead the country in energy development, smart grid and other technologies and provide economic benefit to the state,” said Alan Ettlinger, head of R&D at the New York Power Authority. NYPA will serve as the energy advisor, and SUNY will own and operate the lab.

The facility will have more computing capability than other existing energy labs. “Many entities have the capability of simulating their own utility and distribution system,” said Greg Lennon, NYPA director of business development and AGILE program manager, but it is expected that AGILE will be able to do much more.

AGILE will not focus on either the transmission or distribution system, but will have the ability to simulate both. “We look at this as strategic planning for architecture and infrastructure,” said Lennon. “But also for market policy.”

New York is one of the few states where the transmission system is completely within the purview of the state’s independent system operator. That gives New York regulators the unique ability to innovate in market mechanisms at the wholesale level — and at the distribution level — with the REV initiative.

“The electric utility system is undergoing a revolutionary change, and this facility will place New York squarely at the vanguard of this transformation,” Richard Kauffman, New York’s chairman of energy and finance, said in a statement.

The modeling will allow the public service commission, utilities and other stakeholders to better understand how everything from electric vehicles, to microgrids, to new high-voltage transmission lines could provide value to the grid before they’re deployed.

For example, New York has already identified “*opportunity zones*” where there is grid constraint for potential microgrids. A lab that can model the entire state’s energy footprint will allow vendors to identify additional opportunities for microgrids or other distributed energy resources.

The distribution utilities that will be transformed into platform providers to manage the distributed resources coming onto the system will also benefit, as the facility will help them to test the technology needed to manage these transactions. “Many of the management systems on the distribution level aren’t sufficient to meet the future expectations of a changing grid,” Lennon said of today’s utility systems.

If the facility uses existing SUNY space, it could be open as early as 2016, but if it requires a new building, the timeline is more open-ended. NYPA has an outline of requirements for potential private sector partners, but has not yet put out an RFP.

Once it’s up and running, NYPA said some of the first applications would likely involve synchrophasors, advanced analytics and sensing on the grid for automated applications.

Unlike some other utility or academic labs, the facility will be testing technology that will be deployed onto the New York grid. Ideally, the technology pioneered in the Empire State will then be exported to other states and regions that are investing in similar energy revolutions. “This isn’t R&D for the sake of R&D,” said Lennon.

SAFETY TIPS: A faulty **Wire** can be **Dire**.

BOSTON-POWER AIMS TO RIVAL TESLA WITH GIGAWATT BATTERY FACTORIES

Late last December, lithium-ion battery builder **Boston-Power** announced that it had received \$290 million in “financial support” from Chinese government agencies in order to scale its battery factories. The company’s CEO laid out a goal of “competing with Elon Musk” in the deployment of batteries for electric vehicles.

We spoke with CEO Sonny Wu over the holidays. Wu was a managing director at GSR Ventures and chairman of Boston-Power before he took over the CEO post from founding CEO Christina Lampe-Onnerud in 2012.

Considering the entire \$290 million as a venture round (admittedly a stretch) would bring Boston-Power’s funding total to more than \$600 million since it was founded in 2005. Recent investors have included GSR Ventures, **Foundation Asset Management** and Oak Investment Partners. Investors in earlier rounds included Venrock, GGV Capital and Gabriel Venture Partners.

Boston-Power was founded and funded in the U.S. but has moved its manufacturing to China while keeping some R&D functions stateside. The firm currently has 50 employees in Boston and almost 500 in China.

The company claims that this latest funding event allows Boston-Power to grow its Liyang facility fivefold by 2016 and expand its Tianjin facility capacity to 4 gigawatt-hours by 2017, aiming to reach 8 gigawatt-hours by 2018. Clearly, capex costs for a battery factory in China are cheaper than building a factory in **Reno, Nevada**.

As we’ve reported, Boston-Power uses a lithium-cobalt chemistry, the same battery chemistry found in notebook cells. (The “cobalt” refers to materials used in the battery’s electrodes.) The company has claimed to have refined the casing, anode, cathode and other battery internals for longer life, more cycles, higher energy density and faster charge.

The CEO is enthusiastic about the \$35 billion Chinese EV market, with demand for “high-end lithium-ion batteries hitting 100 gigawatt-hours.” Wu suggests that China will see “significant battery supply constraints over the next three to five years, which we aim to address.”

The battery business is fiercely competitive, with a number of large and long-established incumbents. Products from LG Chem, Panasonic and NEC are already designed into the Chevy Volt, the Tesla Model S, and the Nissan Leaf, respectively.

Wu said, “Our battery is at 200 watt-hours per kilogram, with a longer cycle-life than [comparable products from] Tesla and Panasonic.”

Here’s a guide to gravimetric energy density:

- **117 watt-hours per kilogram:** The level Tesla and Panasonic were achieving in 2008 for the Roadster
- **200 watt-hours per kilogram:** The level Sonny Wu, Boston-Power’s CEO, says the company is achieving today
- **240 watt-hours per kilogram:** The approximate energy density of the batteries in the Tesla S
- **400 watt-hours per kilogram:** According to Tesla’s Elon Musk, the concept of battery-powered transcontinental airplanes becomes “compelling” once batteries hit 400 watt-hours per kilogram (*as per this interview*)
- **400 watt-hours per kilogram:** The level that battery aspirant and ARPA-E grant recipient Envia claimed it could achieve (disingenuously, it turned out)

So Boston-Power’s batteries are designed for Chinese automakers — but don’t think that the competition is the Tesla S; it’s more like the **Tata Nano**.



SAFETY TIPS: *Don't be a fool! Inspect your Electrical Tools Regularly.*

And the difference between Boston-Power's approach and the market entry strategy of Tesla is aimed squarely at solving the "Chindia problem," a term coined by prolific investor Vinod Khosla, who suggests that energy solutions must work in China and India if they are to have any material global impact.

Prius hybrids? Not a solution to the climate or energy problem, according to Khosla. Better to take that money and paint your roof white to improve Earth's albedo. And they certainly don't meet the Chindia test. In order to do so, they would have to compete with the \$2,500 Tata Nano, according to the VC.

Boston-Power is partnering with Chinese auto manufacturers to produce four-seater electric cars with an 80-mile to 120-mile range from a small 13-kilowatt-hour battery pack at a total cost of about \$8,000. That price point seems more aligned with providing a cheap functional vehicle to a growing middle class than a \$100,000 sedan or a \$40,000 family car.

Wu was in China recently and reports that the company and its partners sold 205 cars in a single day in one city. Boston Power's *automotive partners include ZD (Zhidou)*. Wu said, "We are a battery company *enabling our customer* — we co-market." Boston-Power builds a specific battery pack for each vehicle model, including the battery management system.

The CEO says that markets are being driven by some of the 130 million electric scooter owners in China who are now beginning to upgrade to EVs for local commutes and for the convenience of a car that can plug into any AC outlet.

In this type of business in China, it's not just the technology but the levers of power that need to be engineered in order to proceed. Our understanding from a number of sources is that Boston-Power has some of the necessary banking and regional connections to execute on a project of this scale. Of course, Chinese consumers have to cooperate by buying millions of EVs.

The CEO said, "The market for EVs is very exciting given the backdrop of Tesla — but Tesla, that's just the beginning."

GOODYEAR BHO3 CONCEPT TIRE GENERATES ELECTRICITY

One of the biggest hurdles that electric cars face in going mainstream is range anxiety — that dreadful realization that you're in the middle of nowhere and your car might not reach the next charging station. To help combat this, Goodyear came up with its BHO3 concept tire, which generates electricity by converting heat and motion into current as the tire rolls ... and even when it's standing still.

Cars are one the great transportation success stories, but they're also incredibly inefficient. Their main function is to move people from point A to point B, but in doing so they not only waste huge amounts of energy in heat, but also ignore potential sources of energy around them. Unveiled recently at the 85th Geneva International Motor Show, Goodyear's BHO3 concept tire tries to balance that equation by taking a passive device designed to reduce friction and turning it into an electrical generator.

The BHO3 works by turning heat and motion into electricity. It has an ultra-black texture that absorbs light and heat, and the tread is heat-absorbing. This means that the tire gets hotter both through friction while driving and while sitting in the sun, but the tricky bit is getting the tire to turn this heat into electricity.

To do this, the BHO3 is lined with a fishnet pattern of thermo/piezoelectric material. This net turns the heat into electrical current, and its piezoelectric properties also allow it to harvest energy from the tire as it deforms during driving. To keep the tire from overheating, there's also a cooling system in the sidewalls.

Goodyear says that the net also has a bonus feature in that it provides the tire with structural support, so if it's punctured, it can continue to travel at 80 km/h (50 mph) for 80 km (50 mi). It even improves rolling resistance.

The BHO3 is still a concept, so details such as performance or how it hooks into the car's electrical system are sketchy, but it may not be too long before you have to remember to unplug your tire before you change it.



RECORD DECLINE OF ICE SHEETS: FOR THE FIRST TIME SCIENTISTS MAP ELEVATION CHANGES OF GREENLANDIC AND ANTARCTIC GLACIERS

Bremerhaven, 20th August 2014:- Researchers from the Alfred Wegener Institute, Helmholtz Centre for Polar and Marine Research (AWI), have for the first time extensively mapped Greenland's and Antarctica's ice sheets with the help of the ESA satellite CryoSat-2 and have thus been able to prove that the ice crusts of both regions momentarily decline at an unprecedented rate. In total the ice sheets are losing around 500 cubic kilometres of ice per year. This ice mass corresponds to a layer that is about 600 metres thick and would stretch out over the entire metropolitan area of Hamburg, Germany's second largest city. The maps and results of this study are published today in *THE CRYOSPHERE*, an open access journal of the European Geosciences Union (EGU).

“The new elevation maps are snapshots of the current state of the ice sheets. The elevations are very accurate, to just a few metres in height, and cover close to 16 million km² of the area of the ice sheets. This is 500,000 square kilometres more than any previous elevation model from altimetry”, says lead-author *Dr. Veit Helm*, Glaciologist at the **Alfred Wegener Institute in Bremerhaven**.

For the new digital maps, the AWI scientists had evaluated all data by the CryoSat-2 altimeter SIRAL. Satellite altimeter measure the height of an ice sheet by sending radar or laser pulses in the direction of the earth. These signals are then reflected by the surface of the glaciers or the surrounding waters and are subsequently retrieved by the satellite. This way the scientists were able to precisely determine the elevation of single glaciers and to develop detailed maps.

On the basis of further CryoSat-2 the scientists also documented how the elevation has changed over the 2011–2014 period. Ice sheets gain mass through snowfall and lose it due to melting and accelerating glaciers, which carry ice from the interior of the ice sheet to the ocean. “We need to understand where and to which extent the ice thickness across the glaciers has changed. Only then can we analyse the drivers of these changes and find out how much ice sheets contribute to global sea level rise”, says *Veit Helm*.

The team derived the elevation change maps using over 200 million SIRAL data points for Antarctica and around 14.3 million data points for Greenland. The results reveal that Greenland alone is reducing in volume by about 375 cubic kilometres per year. “When we compare the current data with those from the ICES at satellite from the year 2009, the volume loss in Greenland has doubled since then. The loss of the West Antarctic Ice Sheet has in the same time span increased by a factor of 3. Combined the two ice sheets are thinning at a rate of 500 cubic kilometres per year. That is the highest speed observed since altimetry satellite records began about 20 years ago,” says *AWI Glaciologist Prof. Dr. Angelika Humbert*, another of the study's authors.

The areas where the researchers detected the largest elevation changes were Jakobshavn Isbrae (Jakobshavn Glacier) in West Greenland and Pine Island Glacier in West Antarctica. Since February 2014 scientists know that the Jakobshavn Isbrae is moving ice into the ocean at a record rate of up to 46 meters a day. The Pine Island Glacier hit the headlines in July 2013. Back then AWI scientists reported that a table iceberg as large as the area of Hamburg had broken off the tip of its ice shelf. (The AWI press release from the 9th July 2013).

But whereas both the West Antarctic Ice Sheet and the Antarctic Peninsula, on the far west of the continent, are rapidly losing volume, East Antarctica is gaining volume – though at a moderate rate that doesn't compensate the losses on the other side of the continent.

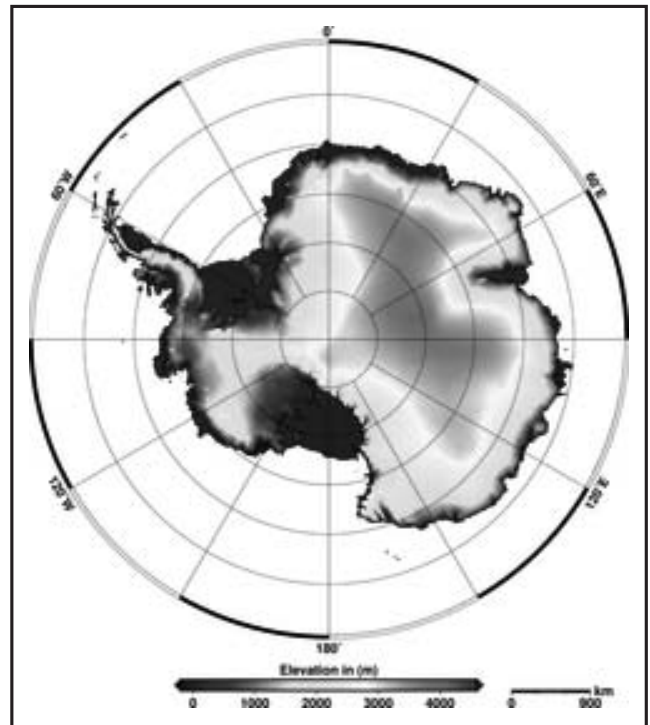

Wear the Right Protective Equipment for the Job.

ENERGY CONSERVATION THROUGH ENERGY EFFICIENCY – 3

Electrical Energy and Losses that affect the Efficiencies (Contd.):

We started to see the magnitude and the very big role played by **I²R** Losses, wherever Electricity is carried. The whole lot of Transmission and Distribution losses are all due to **I²R** Losses and the State wise figures in percentages are given for reference.

OVERALL T&D LOSSES (%)					
State	2007-08	2008-09	2009-10	2010-11	2011-12
Andhra Pradesh	20.3	19.2	18.1	16.1	15.3
Arunachal Pradesh	43.7	48.0	39.1	35.6	34.5
Assam	28.0	29.6	34.8	29.9	27.7
Bihar	39.1	38.0	38.3	37.0	35.0
Chhattisgarh	31.0	28.6	38.7	34.7	32.7
Goa	16.7	21.0	16.6	17.4	17.6
Gujarat	23.8	22.8	24.5	22.7	22.3
Haryana	28.1	25.7	26.8	24.4	22.7
Himachal Pradesh	13.5	13.2	14.7	14.6	14.5
Jammu & Kashmir	61.9	61.3	63.0	60.0	58.5
Jharkhand	42.3	43.0	38.5	33.5	40.8
Karnataka	25.3	23.3	21.4	20.1	19.6
Kerala	19.9	19.9	19.2	19.1	18.6
Madhya Pradesh	40.1	39.0	35.6	34.1	32.6
Maharashtra	29.1	26.5	25.2	22.5	21.6
Manipur	48.4	51.1	45.8	43.3	38.0
Meghalaya	33.4	31.2	34.0	30.0	28.4
Mizoram	24.9	32.6	37.0	35.4	34.3
Nagaland	36.4	31.0	36.5	30.8	28.1
Puducherry	13.8	13.7	13.5	13.5	13.5
Punjab	21.5	18.5	19.7	17.8	16.8
Rajasthan	35.5	31.9	29.9	27.6	24.8
Sikkim	22.3	34.0	40.6	42.4	38.8
Tamil Nadu	18.0	18.0	18.0	18.0	17.0
Tripura	23.4	24.1	24.7	20.9	20.1
Uttar Pradesh	32.6	28.6	32.3	28.9	24.4
Uttarakhand	29.7	28.0	24.5	22.5	20.5
West Bengal	24.3	23.3	23.8	23.5	22.3
Source: Planning Commission					

The All India figure is around 25%. With Electricity being around 900 Billion Units, we can calculate the quantum of Energy spent in Transmission and distribution losses which can be reduced substantially.

The T&D Technical losses depend on the type of conductors used, transformer capacity, and other equipments used for transmission and distribution of electricity. These losses are intrinsic to power transmission system and all the countries report some percentage of technical losses. The transmission and distribution losses in the developed countries are in the range of 4 to 8 per cent. Countries in Europe and United States of America have T&D losses of about 6 to 8 per cent. Japan and Germany have reported losses of 4 per cent. Russia, on the other hand, has reported losses of around 12 per cent. India compares badly to the T&D loss average of the developed world. Even China has been able to check its T&D losses with just 7 per cent loss reported.

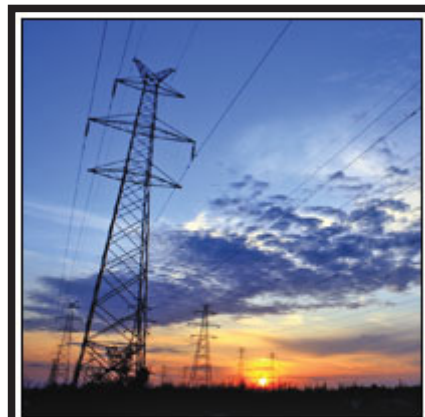

India is focusing on extra high-voltage transmission lines to reduce Technical Losses

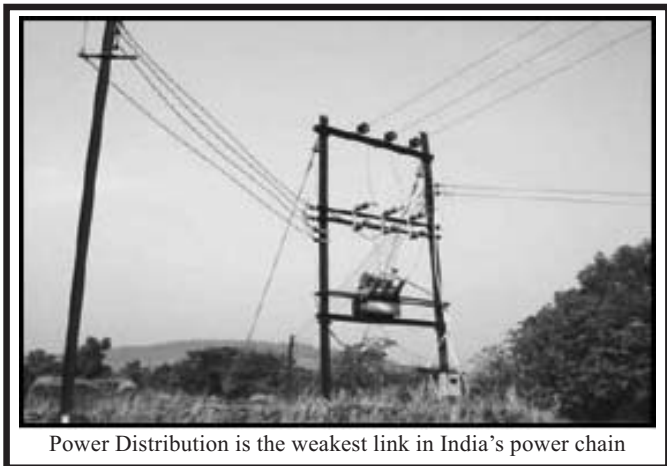
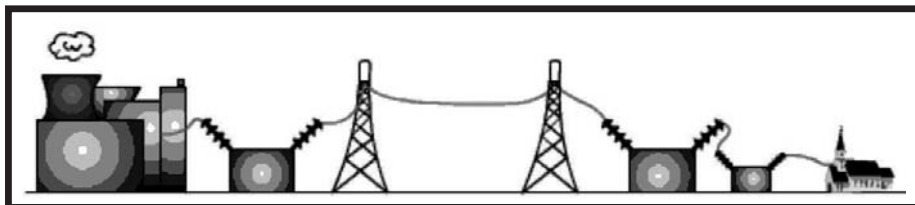

Power Distribution is the weakest link in India's power chain



Apart from addressing the Transmission Voltages for reducing the quantum of Current and the losses, the big area that needs attention is the last end Distribution Transformers. Though there are some improvements in some of the states, the total number of Distribution Transformers all over the country is about 25 Lakhs with the largest number of Transformers being 100 KVA (around 20 Lakhs). BEE has come out with STAR Markings for Distribution Transformers, but the country still operates with

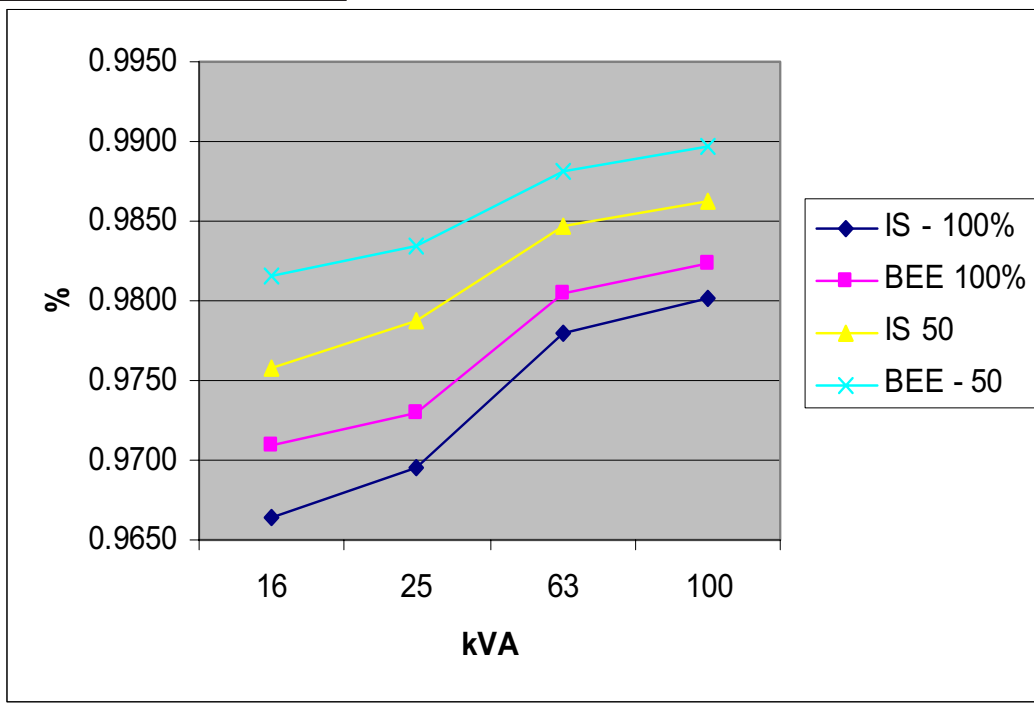

very huge number of old Transformers which are repaired often (failure rate at one time was around 25 to 30% per annum, which have been improving in some of the states) and the losses would be much higher than specified.

Current BEE Standards and Star Marking specify Efficiencies of the order of 98, 99% etc and some of the important informations are as under.

A rough estimate of losses in Distribution Transformers alone may account for total losses of Billions of KWHs – Units.

100 KVA

Full Load Losses as per REC = 260 + 1760 Watts = 2020 Watts
 +10% Estimate = 2222 Watts

Full Load Losses of 5 STAR Transformer = 1500 Watts

Total losses of 100 KVA Ratings alone work out to about 18 Billion Units per annum and all other ratings put together, the figure could be around 25 Billion Units, with scope to save about 25 to 30% with Transformers of current standards.

The above losses of Transformers worked out and shown above include both I²R Losses and the Magnetic or Iron Losses about which we will deal in the coming chapter.

Before we move on to analyse about another important loss namely Magnetisation or Iron Losses, it will be apt to understand about the huge quantum of losses suffered in Billions of Connections, Terminations and Joints.

(To be continued)

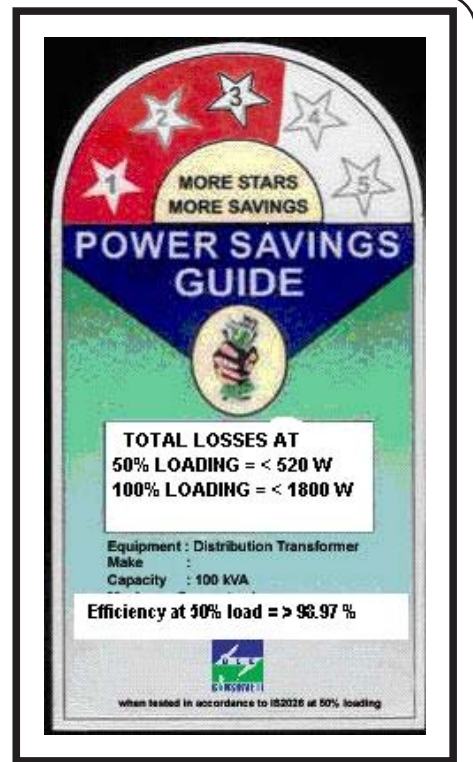

S. Mahadevan, B.E., F.I.E., M.B.A.,
 Consultant,
 Energy and Energy Efficiency,
 Mobile: 98401 55209

WHAT MADE THE DIFFERENCE – (SELF-CONFIDENCE)

The business executive was deep in debt and could see no way out. Creditors were closing in on him. Suppliers were demanding payment. He sat on the park bench, head in hands, wondering if anything could save his company from bankruptcy.

Suddenly an old man appeared before him. “I can see that something is troubling you,” he said. After listening to the executive’s woes, the old man said, “I believe I can help you.”

He asked the man his name, wrote out a check, and pushed it into his hand saying, “Take this money. Meet me here exactly one year from today, and you can pay me back at that time.” The business executive saw in his hand a check for \$500,000, signed by John D. Rockefeller, then one of the richest men in the world!

“I can erase my money worries in an instant!” he realized. But instead, the executive decided to put the un-cashed check in his safe. Just knowing it was there might give him the strength to work out a way to save his business, he thought.

With renewed optimism, he negotiated better deals and extended terms of payment. He closed several big sales. Within a few months, he was out of debt and making money once again.

One year later, he returned to the park with the un-cashed check. At the agreed-upon time, the old man appeared. But just as the executive was about to hand back the check and share his success story, a nurse came running up and grabbed the old man.

“I’m so glad I caught him!” she cried. “I hope he hasn’t been bothering you. He’s always escaping from the home and telling people he’s John D. Rockefeller.” And she led the old man away.

The astonished executive just stood there, stunned. All year long he’d been wheeling and dealing, buying and selling, convinced he had half a million dollars behind him.

Suddenly, he realized that it wasn’t the money that had turned his life around. It was his newfound self-confidence that gave him the power to achieve anything he went after.

ACHIEVING LONGEVITY

Achieving longevity would be a hollow victory indeed if all it gave us was more time on this earth. The goal of having a long life goes hand in hand with the idea of a vital, happy and healthy life. In fact, enjoying excellent health is probably the most important factor in achieving longevity. If you think about it, would you really want longevity without quality?

Your odds of achieving optimal health will profoundly increase by eating a high quality diet. A high enzyme diet consisting of raw fruits, vegetables, seeds, nuts and grains has proven to be the most healing and cleansing diet possible. Why is this so? Consuming a mostly raw diet allows the body to cleanse, heal and build, while eating a diet of predominately cooked food puts a tremendous strain on the body.

To understand why eating a diet high in cooked foods is harmful, it is necessary to understand the role enzymes play. Enzymes are in the cells of every living plant. It is enzyme activity that accomplishes all biological work from blinking the eye, to lifting a finger, to having a thought. Scientists now agree that enzymes are 'the stuff of life'.

When we eat, we need enzymes to help digest food. If the food we are eating is raw, whether it is an apple, a carrot, a lettuce leaf or a strawberry - if it is really fresh, it will contain all the enzymes we need to aid in digestion, assimilation and elimination.

However, when food is cooked beyond 118 degrees F the heat kills all naturally occurring enzymes and our body must manufacture its own digestive enzymes to do the job. Although our bodies are designed to manufacture all the enzymes it needs, constantly calling upon it to create enzymes for the digestive process poses a problem. When the body is busy digesting food, it is unable to divert the necessary energy to make the type of enzymes needed to do other tasks. There is a tug of war between the demands of the digestive system for a constant supply of digestive enzymes and the needs of the body for the metabolic enzymes vital for cleansing, healing and building. Without an adequate supply of metabolic enzymes, over time, we suffer.

What does this suffering look like? It looks like ageing, it looks like disease, indigestion, constipation, acid reflux, age spots, fatigue, lethargy, wrinkles, bad skin, bags under the eyes, declining eyesight, aches and pains, declining memory, mood swings, irritability, allergies, weight gain, brain fog, candida, certain cancers, gallbladder surgery, heart attacks, arthritis, depression, and the list goes on and on. This decline in health and vitality is usually considered to be a normal part of the ageing process. But it is really the result of two facts; over time, the body loses its ability to manufacture enzymes and, when we eat food that is cooked, it forces our bodies to manufacture enzymes for digestion, instead of enzymes that could be used for healing. Ultimately when we don't have enough enzymes to carry out the basic needs of life, we die.

How can you begin the process of eating high enzyme foods so that your body will be freed up to manufacture the enzymes it needs to cleanse, heal and re-build? - Easy! Consume 70-100% of your food raw, taken from the fruit, vegetable groups, sprout your nuts, seeds and grains. You will be surprised at the tremendous selection of wonderful foods to choose from, and at how quickly your taste buds convert from liking processed foods to craving fresh unprocessed healthy fare. Knowing that even in the most frightening of circumstances a programme of clean food and living can allow the body to create a miracle of healing, think how it will affect you to embark on this lifestyle before the signature symptoms of so-called old age appear. Taking matters of health into your own hands is also an act of empowerment and healing on its own.

Life is indeed an adventure of wonder and joy - no time for dress rehearsals, no time to waste feeling like a caterpillar who yearns to fly. You just cannot UNknow what you've learned so far, and you can't kid yourself either! Now you have the information, just what exactly are you going to do with it?!

*Whatever you think you can do or believe you can do, begin it - **Action has grace, magic and power in it.***

Source: Pat reeves, nutritional therapist.

HUMOUR - TELL THE TRUTH

A person had a wife and 12 children and needed to move as his rental agreement was coming to an end for the home where he lived but was having difficulty in finding a new home. When he said he had 12 children, no one would rent a home to him because they knew that the children would destroy the home. He could not say that he had no children, he could not lie, after all, common morality demands it. So, he had an idea : he sent his wife for a walk to the cemetery with 11 children. He took the remaining one with him to see homes with the Real Estate Agent.

He liked one of the homes and the agent asked : "How many children do you have?"

He answered : "12 children".

The agent asked "Where are the others?"

He answered, with a sad look, "They are in the cemetery with their mother".

And that's the way he was able to rent a home for his family without lying.

MORAL : It is not necessary to lie, one only has to choose the right words.

Don't lie... be creative...

வந்து பாருங்கள் - ஈஞ்சம்பாக்கம்



கலையில் ஈடுபட்டார்கள். உயிர்த்துடிப்பு மிக்க ஓவியங்களையும் கைவினைப் பொருட்களையும் உருவாக்கத் தொடங்கினார்கள்.

1950களின் இறுதியில் சென்னை ஓவியக் கல்லூரியில் பயின்ற பல ஓவியர்கள் கே.சி.எஸ். பணிக்கருடன் சேர்ந்து சோழ மண்டலம் ஓவிய கிராமத்தை உருவாக்கியுள்ளார்கள். இங்கு ஓவியர்களே எல்லாவற்றையும் கட்டினார்கள். வீடுகள், ஓவியக் கூடங்கள், கண்காட்சி வைப்பதற்கான சித்திரக்கூடம், நாடக அரங்கு போன்ற பலவற்றை ஓவியர்கள் உருவாக்கிக் கொண்டார்கள். இன்று ஆசியாவிலேயே சிறந்த ஓவியக் கிராமம் என்று சொல்லுமளவுக்கு சோழ மண்டல ஓவிய கிராமம் விளங்குகிறது.

விருந்தினர் மாளிகை, ஓவியக் கண்காட்சி வைக்க அறைகள் ஆகியவையும் உள்ளன. வளர்ந்து வரும் ஓவியர்களுக்கு உதவ 'பிராக்ரசிவ் பெயிண்டர்ஸ் அசோசியேஷன்' (PPA) என்ற அமைப்பும் நடத்தப்படுகிறது. ஓவியப் பிரியர்களுக்கு, குழந்தைகளுக்கு என ஓவியப் பயிற்சி வகுப்புகளையும் நடத்துகிறார்கள்.

Courtesy: தி இந்து, ஐய வருட மலர் 2014

ஓவிய கிராமம்

ஓவியக் கலையைத் தீவிரமாகச் செயல்படுத்த விரும்பிய ஓவியர்கள் பலரது கூட்டு முயற்சியில் உருவானது சென்னை கடற்கரைச் சாலையில், ஈஞ்சம்பாக்கத்தில். உள்ள சோழமண்டல ஓவிய கிராமம். இதற்கான முதல் முயற்சி 1964-ல் மேற்கொள்ளப்பட்டது. இந்த முயற்சியின் ஒரு பகுதியாக ஓவியர்கள், கைவினைப் பொருள்களை உருவாக்கி அவற்றை விற்க தொடங்கினார்கள். 1966

ஏப்ரல் 13-ம் நாளன்று, கைவினைப் பொருட்கள் விற்பனை மூலம் கிடைத்த தொகையைக் கொண்டு சென்னை கிழக்குக் கடற்கரைச் சாலையில் மாமல்லபுரம் போகும் வழியில் கடலோரத்தில் 10 ஏக்கர் நிலத்தை விலைக்கு வாங்கினார்கள். அந்த ஆண்டு மே மாதம் முதல் கட்டமாக, ஏழு ஓவியர்கள் அந்தப் பகுதியில் குடியேறினார்கள். குடியேறிய ஓவியர்கள் சுதந்திரமான மனநிலையுடன் இயற்கை எழில் சூழ்ந்த, அந்தப் பகுதியில் படைப்புக்

20 MOST PEACEFUL COUNTRIES IN THE WORLD - 6

ICELAND



Iceland was also ranked as one of the most peaceful countries in the world, staying out of the main conflicts in the world. Iceland seldom or never hits the headlines and despite the collapse of the Icelandic banks several years ago, the country is remained as an amazing place of spectacular natural beauty. Tourists from all parts of the world come to Iceland to view its huge glaciers and raging volcanoes, as well as numerous unique natural and cultural attractions in Reykjavik, the capital of Iceland.

*(To be continued)
Courtesy: Amerikanki*

சிறு தானியங்களினால் தீரும் நோய்கள்



தினை:

மன அமைதி, இரத்தத்தில் உள்ள புற்றுநோய், சர்க்கரை, கொழுப்பு, மாரடைப்பு, ஆஸ்துமா, மார்க்புற்று, நரம்பு தளர்ச்சி



குதிரைவாலி:

சர்க்கரை, இரத்தசோகை, அஜீரணம், உடல் கழிவு சீராக வெயியேறுதல்.



கம்பு:

உடல் குடு, வாய்ப்புண், வயிற்றுப்புண், குடல்புண், மலச்சிக்கல், பசியின்மை, கண்பார்வை கோளாறு, இதயத்தை வலுவாக்க, இரத்தத்தைச் சுத்திகரிக்க, உடலில் தேவையற்ற நீரை வெளியேற்றுவது, நோய் எதிர்ப்பு சக்தி, விந்து விருத்தி உண்டாகும்.



சோளம்:

சர்க்கரை, அஜீரணம், இரத்தசோகை, சிறுநீரக கோளாறு, கண் குறைபாடு, உடல் பருமன், வாய்ப்புண், வாய்நாற்றம், வயிற்றுப்புண்.



வரகு:

மூட்டுவலி, மன அமைதி, உடல் பருமன், சர்க்கரை, கொழுப்பு, புற்றுநோய் பாதிப்பு, மலச்சிக்கல், மாதவிடாய் கோளாறு, கல்லீரல், பித்தப்பை, நின நீர்சுரப்பு புற்று.



கொள்ளு:

உடல் பருமன், சிறுநீரக கல், சர்க்கரை, வாதம், மூட்டுவலி, குடல் புழுக்கல், கண் அலர்ஜி, மூலம், சளி, இருமல், காய்ச்சல், கொழுப்பு, பெப்டிக் அல்சர், வாயு தொந்தரவு, மாதவிடாய் குறைபாடு, சருமநோய்.



சாமை:

சர்க்கரை, விந்து விருத்தி, ஆண்மை குறைபாடு, செரிமானக் கோளாறு.

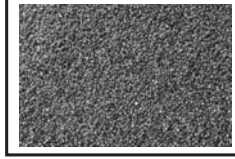

கேழ்வரகு:

உடல் குடு, சர்க்கரை, நீர் எரிச்சல், சரும நோய், சிறுநீரக கற்கள், ரத்தசோகை.

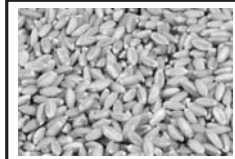

கோதுமை:

முதுகு வலி, மூட்டு வலி, வயிறு உப்புசம், உடல் பலம், ஆண்மை விருத்தி, கபம், காசநோய்.

இன்றைய காலகட்டத்தில் ஆரோக்கியமாக வாழ்வதற்கு ஒரே வழி துரித உணவு கலாச்சாரத்தை விட்டு, பாரம்பரிய உணவு கலாச்சாரத்திற்கு மாறுவதே ஆகும். இயற்கை தானியங்களான தினை, கம்பு, வரகு, சாமை, குதிரைவாலி, சோளம், கொள்ளு, கேழ்வரகு, கோதுமை ஆகியவற்றை பயன்படுத்தி **நோய் இல்லாத ஆரோக்கியமான வாழ்வை பெறுவோம்.**

இயற்கை வாழ்வியல், இயற்கை வேளாண்மை, இயற்கை உணவு, இயற்கை மருத்துவம், இவையாவும் இயற்கை வழிமுறையில் மட்டும்தான் கிடைக்கும்

தானியங்கள்	புரதசத்து	நார்சத்து	தாதுச்சத்து	இரும்பு சத்து	சுண்ணாம்பு சத்து
கம்பு	10.8	1.3	2.3	19.9	38
கேழ்வரகு	7.3	3.6	2.7	3.9	344
தினை	12.3	8	3.3	2.8	31
பனிவரகு	12.5	2.2	1.9	0.8	14
வரகு	8.3	9	2.6	0.5	27
சாமை	7.7	7.6	1.5	9.3	17
குதிரைவாலி	11.2	10.1	4.4	15.2	11

ஆரோக்கியம்

ஐஸ்வர்யம்

ஆனந்தம்

Courtesy: Arogya foods, Kumbakonam

ARUNA ASAF ALI (1909-1996)

Aruna Asaf Ali (16 July 1909 – 29 July 1996), born **Aruna Ganguly**, was an Indian independence activist. She is widely remembered for hoisting the Indian National Congress flag at the Gowalia Tank maidan in Bombay during the Quit India Movement, 1942. She was 87 years old at the time of her death.



Early life

(AADIL) Aruna Ali was born as Aruna Ganguly on 16 July 1909 at Kalka, Punjab, British India, but now in the state of Haryana into a Bengali Brahmo family. She was educated at Sacred Heart Convent in Lahore and then in Nainital. She graduated and worked as a teacher. She taught at the Gokhale Memorial School in Calcutta. She met Asaf Ali, a leader in the Congress party at Allahabad and married him in 1928, despite parental opposition on grounds of religion (she was a Brahmo while he was a Muslim) and age (a difference of more than 20 years).

Freedom struggle: early days

She became an active member of Congress Party after marrying Asaf Ali and participated in public processions during the Salt Satyagraha. She was arrested on the charge that she was a vagrant and hence not released in 1931 under the Gandhi-Irwin Pact which stipulated release of all political prisoners. Other women co-prisoners refused to leave the premises unless she was also released and gave in only after Mohandas K. Gandhi intervened. A public agitation secured her release.

In 1932, she was held prisoner at the Tihar Jail where she protested the indifferent treatment of political prisoners by launching a hunger strike. Her efforts resulted in an improvement of conditions in the Tihar Jail but she was moved to Ambala and was subjected to solitary confinement. She was politically not very active after her release.

Family

Her father Upendranath Ganguly hailed from Barisal district of Eastern Bengal but settled in the United Province. He was a restaurant owner and a very adventurous man. Mother Ambalika Devi was the daughter of Trailokyanath Sanyal, a renowned Brahmo leader who wrote many beautiful Brahmo hymns. Upendranath Ganguly's younger brother Dhirendranath Ganguly (D G) was one of the earliest film directors.

Another brother Nagendranath, a soil biologist was married to Rabindranath Tagore's only surviving daughter Mira Devi though they got separated after sometime. Her sister, Purnima Banerjee was a member of the Constituent Assembly of India.

Face of Quit India movement

On 8 August 1942, the All India Congress Committee passed the Quit India resolution at the Bombay session. The government responded by arresting the major leaders and all members of the Congress Working Committee and thus tried to pre-empt the movement from success. A young Aruna Asaf Ali presided over the remainder of the session on 9 August and hoisted the Congress flag at the Gowalia Tank maidan. This marked the commencement of the movement. The police fired upon the assembly at the session. Aruna was dubbed the *Heroine of the 1942 movement* for her bravery in the face of danger and was called *Grand Old Lady of the Independence movement* in her later years. Despite absence of direct leadership, spontaneous protests and demonstrations were held all over the country, as an expression of desire of India's youth to achieve independence.

Countdown to Independence

An arrest warrant was issued in her name but she went underground to evade the arrest and started underground movement in year 1942. Her property was seized and sold. In the meanwhile, she also edited *Inquilab*, a monthly magazine of the Congress Party, along with Ram Manohar Lohia. In a 1944 issue, she exhorted youth to action by asking them to forget futile discussions about violence and non-violence and join the revolution. Leaders such as Jayaprakash Narayan and Aruna Asaf Ali were described as "the Political children of Gandhi but recent students of Karl Marx." The government announced a reward of Rs.5,000/- for her capture. She fell ill and was for a period hiding in Dr Joshi's Hospital in Karol Bagh in Delhi. Mahatma Gandhi sent her a hand-written note to her to come out of hiding and surrender herself – as her mission was accomplished and as she could utilize the reward amount for the Harijan cause. However, she came out of hiding only after the warrant against her was withdrawn in 1946. She treasured the note from the Mahatma and it adorned her drawing room. However, she also faced criticism from Gandhi for her support of the Royal Indian Navy Mutiny, a movement she saw as the single greatest unifying factor of Hindus and Muslims at a time that was the peak of the movement for Pakistan.

Post-Independence

She was a member of the Congress Socialist Party, a caucus within the Congress Party for activists with socialist leanings. Disillusioned with the progress of the Congress Party on socialism she joined a new party,

Socialist Party in 1948. She however left that party along with Metadata Granary and they visited Moscow along with Rajani Palme Dutt. Both of them joined the Communist Party of India in the early 1950s. On domestic front, she was bereaved when Asaf Ali died in 1953.

In 1954, she helped form the National Federation of Indian Women, the women's wing of CPI but left the party in 1956 following Nikita Khrushchev's disowning of Stalin. In 1958, she was elected the first Mayor of Delhi. She was closely associated with social activists and secularists of her era like Krishna Menon, Vimla Kapoor, Guru Radha Kishan, Premsagar Gupta, Rajani Palme Joti, Sarla Sharma and Subhadra Joshi for social welfare and development in Delhi. She was the first elected Mayor of Delhi.

She and Narayanan started Link publishing house and published a daily newspaper, *Patriot* and a weekly, *Link* the same year. The publications became prestigious due to patronage of leaders such as Jawaharlal Nehru, Krishna Menon and Biju Patnaik. Later she moved out of the publishing house due to internal politics, stunned by greed taking over the creed of her comrades. In 1964, she rejoined the Congress Party but stopped taking part in active politics. Despite reservations about the

emergency, she remained close to Indira Gandhi and Rajiv Gandhi.

Legacy

Aruna Asaf Ali was awarded International Lenin Peace Prize for the year 1964 and the Jawaharlal Nehru Award for International Understanding in 1991. She was awarded India's second highest civilian honour, the **Padma Vibhushan** in her lifetime in 1992, and finally the highest civilian award, the **Bharat Ratna**, posthumously in 1997. In 1998, a stamp commemorating her was issued. *Aruna Asaf Ali marg* in New Delhi was named in her honour. All India Minorities Front distributes the *Dr Aruna Asaf Ali Sadbhawana Award* annually.

Anecdote

Aruna Asaf Ali was well known for her Spartan lifestyle – she used public transport. In her eighties, once she was travelling in a crowded bus in Delhi and no seat was vacant. A fashionable young lady also boarded the bus and a gentleman trying to impress her, vacated his seat. This lady, in turn, offered the seat to Aruna Asaf Ali who accepted it. At this, that man protested, saying to the lady, "I vacated that seat for your sake, sister." Aruna Asaf Ali retorted with her quick wit, "Never mind, mother always comes before sister."

HUMOUR - Collection of Tongue Twisters



- 1.If you understand, say "understand". If you don't understand, say "don't understand". But if you understand and say "don't understand".How do I understand that you understand? Understand!
- 2.I wish to wish the wish you wish to wish, but if you wish the wish the witch wishes, I won't wish the wish you wish to wish.
- 3.Sounding by sound is a sound method of sounding sounds.
- 4.A sailor went to sea to see, what he could see. And all he could see was sea, sea, sea.
5. If two witches were watching two watches, which witch would watch which watch?
6. I thought a thought. But the thought I thought wasn't the thought I thought I thought. If the thought I thought I thought had been the thought I thought, I wouldn't have thought so much.

7. Mr Inside went over to see Mr Outside. Mr Inside stood outside and called to Mr Outside inside. Mr Outside answered Mr Inside from inside and Told Mr Inside to come inside. Mr Inside said "NO", and told Mr Outside to come outside. Mr Outside and Mr Inside argued from inside and outside about going outside or coming inside. Finally, Mr Outside coaxed Mr Inside to come inside, then both Mr Outside and Mr Inside went outside to the riverside.
8. SHE SELLS SEA SHELLS ON THE SEA SHORE, BUT THE SEA SHELLS THAT SHE SELLS, ON THE SEA SHORE ARE NOT THE REAL ONES
9. If one doctor doctors another doctor does the doctor who doctors the doctor doctor the doctor the way the doctor he is doctoring doctors? Or does the doctor doctor the way the doctor who doctors doctors? "When a doctor falls ill another doctor doctor's the doctor. Does the doctor doctoring the doctor doctor the doctor in his own way or does the doctor doctoring the doctor doctors the doctor in the doctor's way".
10. We surely shall see the sun shine shortly. Whether the weather be fine, Or whether the weather be not, Whether the weather be cold Or whether the weather be hot, We'll weather the weather Whatever the weather, Whether we like it or not. watch? Whether the weather is hot. Whether the weather is cold. Whether the weather is either or not. It is whether we like it or not.

WILHELM WEBER (1804 – 1891)

Early years

Weber was born in Wittenberg, where his father, Michael Weber, was professor of theology. Wilhelm was the second of three brothers, all of whom were distinguished by an aptitude for science. After the dissolution of the University of Wittenberg his father was transferred to Halle in 1815. William had received his first lessons from his father, but was now sent to the Orphan Asylum and Grammar School at Halle. After that he entered the University, and devoted himself to natural philosophy. He distinguished himself so much in his classes, and by original work, that after taking his degree of Doctor and becoming a *Privatdozent* he was appointed Professor Extraordinary of natural philosophy at Halle.



Career

In 1831, on the recommendation of Carl Friedrich Gauss, he was hired by the university of Göttingen as professor of physics, at the age of twenty-seven. His lectures were interesting, instructive, and suggestive. Weber thought that, in order to thoroughly understand physics and apply it to daily life, mere lectures, though illustrated by experiments, were insufficient, and he encouraged his students to experiment themselves, free of charge, in the college laboratory. As a student of twenty years he, with his brother, Ernst Heinrich Weber, Professor of

Anatomy at Leipzig, had written a book on the *Wave Theory and Fluidity*, which brought its authors a considerable reputation. Acoustics was a favourite science of his, and he published numerous papers upon it in *Poggendorffs Annalen*, Schweigger's *Jahrbücher für Chemie und Physik*, and the musical journal *Carcilia*. The 'mechanism of walking in mankind' was another study, undertaken in conjunction with his younger brother, Eduard Weber. These important investigations were published between the years 1825 and 1838. Gauss and Weber constructed the first electromagnetic telegraph in 1833, which connected the observatory with the institute for physics in Göttingen.

In December 1837, the Hannoverian government dismissed Weber, one of the Göttingen Seven, from his post at the university for political reasons. Weber then travelled for a time, visiting England, among other countries, and became professor of physics in Leipzig from 1843 to 1849, when he was reinstated at Göttingen. One of his most important works, co-authored with Carl Friedrich Gauss and Carl Wolfgang Benjamin Goldschmidt, was *Atlas des Erdmagnetismus: nach den Elementen der Theorie entworfen* (*Atlas of Geomagnetism: According to the Elements of the Theory of Design*), a series of magnetic maps, and it was chiefly through his efforts that magnetic observatories were instituted. He studied magnetism with Gauss, and during 1864 published his *Electrodynamic Proportional Measures* containing a system of absolute measurements for electric currents, which forms the basis of those in use. Weber died in Göttingen, where he is buried in the same cemetery as Max Planck and Max Born. He was elected a foreign member of the Royal Swedish Academy of Sciences in 1855. In 1856 with Rudolf Kohlrausch (1809–1858) he demonstrated that the ratio of electrostatic to electromagnetic units produced a number that matched the value of the then known speed of light. This finding led to Maxwell's conjecture that light is an electromagnetic wave. This also led to Weber's development of his theory of electrodynamics. Also, the first usage of the letter "c" to denote the speed of light was in an 1856 paper by Kohlrausch and Weber. The SI unit of magnetic flux, the weber (symbol: Wb) is named after him.

POWER YOUR MIND – WHERE IS PEACE?

In this world of hue and cry
You want peace then go and try
Oh, foolish mind go to the bottom
Of the ocean
If you wish then go high in the sky
Go to caves and climb
The mountains high.

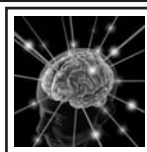

Courtesy: Swami Srikantananda

Go, go and have a holy dip
In all the holy streams
But I tell you my friend at last
All these will prove An empty dream.
In you is hidden the abode of peace
Dive deep and enjoy
Within you eternal peace.

TIRUKKURAL AND MANAGEMENT IN A 'NUTSHELL' – 25



This is Cricket season now and IPL Matches are very well attended and are very popular among all TV Viewers as well. We have opportunities to see varieties of Leadership among the various Captains. We see many Captains showing excess joy in success and deep disappointment and even depression in defeats. M.S. Dhoni, the Indian Captain as well as the Captain of an IPL Team CSK, has always been praised for his Calmness and Steadiness irrespective of Successes and

Defeats. This is considered an important Characteristic needed for a Leader. This is dealt as “EQUANIMITY” in some of the Management treatises.

Tiruvalluvar deals with this in quite a few places and the following 2 Kurals will bring out the essence.

Inbam Vizhaiyaan Idumbai Iyalbuenbaan
Thunbam Urudal Ilan Kural 628

இன்பம் விழையான் இடும்பை இயல்புஎன்பான்
துன்பம் உறுதல் இலன் குறள் 628

“ Who seek not joy, deem grief norm
By sorrows do not come to harm”.

Inbaththul Inbam Vizhayadan Thunbaththul
Thunbam Uruthal Ilan Kural 629

இன்பத்துள் இன்பம் விழையாதான் துன்பத்துள்
துன்பம் உறுதல் இலன். குறள் 629

“ In joy to joy who is not bound
In grief he grieves not dual round!”

HOME FESTIVALS - 6

ஆனி – Aani (June/July)

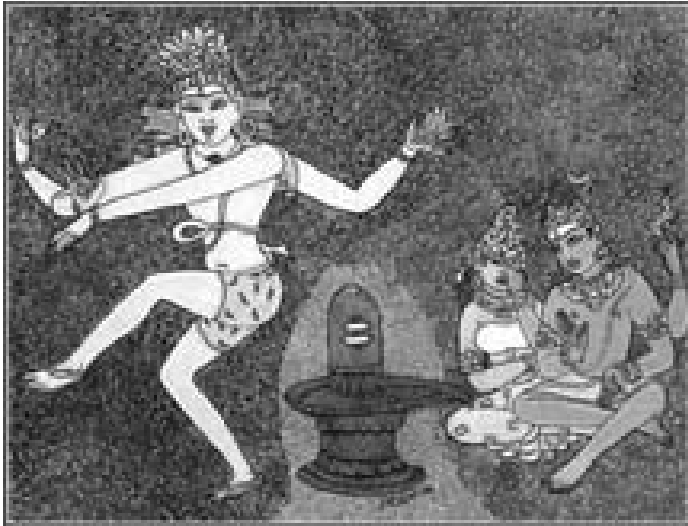

This is the one month of the year when there are no home festivals – coinciding not uncoincidentally with an intense month of agricultural effort. However, during Ani, major temple festivals are held for Lord Siva as Nataraja, King of Dance (above left), and for Siva and Parvati.

(To be continued)

*There are great scholars in their own respective fields who may otherwise be fools. Here is a story. A doctor, a logician, an astrologer and a musician came to meet the King to receive gifts. When the king expressed his appreciations of their talents the Minister butted in to say that they were experts in their own fields but knew nothing else. To test this, an order was passed by the king that they should cook their own food and after lunch they should meet him in the afternoon. The **astrologer** who went to a tree to bring a leaf, saw bad omens and stuck to the tree. The **doctor** found fault with every vegetable from the health point of view and came back from the market empty-handed. The **logician** was arguing within himself whether the container was the substratum for the contents or the contents were the substratum for the container, on purchasing ghee in a leafy vessel. The **musician** got angry that the sound of the boiling rice from the cooking pot was not rhythmical and broke the pot. At the appointed time, none of them turned up and on enquiry, the king learnt they were all a hopeless mess.*

– H.H. SHRI PARAMACHARYA

PROTOTYPE ELECTRIC VEHICLE PASSES FIRST TEST ON ROAD TO ANTARCTICA

The Venturi Antarctica, a prototype electric vehicle designed to tackle the harsh climates of Antarctica recently completed its first test drive in the Southern Alps of Europe. Manufactured by Venturi Automobiles, the joystick-controlled prototype seats five and can reach a top speed of 25 km/h (15 mph) on snow tracks and 45 km/h (27 mph) on wheels. When fully developed, the electric vehicle will allow scientists to drive to research sites without any risk of contaminating the samples to be collected.

Contamination is a huge concern, as even one additional molecule can threaten the integrity of a sample. Scientists typically cover the last 8 or 10 km (5 or 6 mi) to a research site by foot or on skis. This is where The Venturi Antarctica will help, say its engineers, by conveying them to the sample site risk-free.

"They need a vehicle that doesn't contaminate the soil and air – the area of study must be clean of human activities," Franck Baldet, a testing engineer with Venturi Automobiles tells Gizmag. "It's crucial to have the most virgin environment to be deeply studied."

Measuring 3 m long, 2.3 m wide and 1.8 m tall (9.8 x 7.5 x 5.9 ft), the prototype uses a 23 kWh battery, two electric motors and an eight-wheel drive. Expert drivers tested its maneuverability in the Southern Alps on slopes with inclines up to 40 percent in very low temperatures and a range of snow conditions from tough to very icy. Dynamic maneuvers such as on the spot 360-degree rotation, climbing, time response to command input and hitting the panic brakes, were tested.

The goal was to check how intuitively the vehicle responded to joystick controls, in order to allow future untrained drivers and scientific personnel to easily operate the Venturi Antarctica without specific training.

"We can affirm that it is the easiest vehicle to drive with a joystick," says Baldet. "We performed autonomy driving sessions and successfully reached 20 km (12 mi) at a constant 20 km/h (12 mph) speed, as specified by the scientists needs and the French Polar Institute (IPEV)."

The engineers also evaluated the vehicle's ability to charge at various low temperatures. While the Venturi Antarctica can currently be driven in sub-zero temperatures and on different types of snow, the challenge is to get it to work at -40° C (40° F) before it can be sent to Antarctica. Ongoing work includes finding light materials that are tolerant to extreme weather and improving the battery's efficiency while still limiting its weight.

"The Venturi Antarctica has a good behaviour in the cold," Baldet tells us. "Sending it to the white continent will depend on the results we have with batteries' testing sessions in extreme cold conditions."

With a different type of chassis, the prototype could also be adapted for different applications, such as using it for transporting people and equipment in ski resorts.

Source: Venturi Automobiles

PROTOTYPE ELECTRIC VEHICLE PASSES FIRST TEST ON ROAD TO ANTARCTICA



Safe Earthing Electrode | Back Fill Compounds | Lighting Arresters



ASHLOK

YOUR ULTIMATE SOLUTION FOR EARTHING

India | U.A.E.

www.ashlok.in | +91 94440 87356 | earthing@ashlok.in

15

Glorious Years of Earthing

